

## DLA 2-CYCLE GAS ENGINES FOR MODEL AIRCRAFT

This Manual presents the necessary information for the operation of all DLA 2-cycle gasoline, Model Airplane Engines. DLA 32, 58, 64, 64-I2, 116cc, 116cc-I2, 180cc, 128cc, 232cc QUAD

DLA 32cc



DLA 58cc



DLA 64cc Twin-Boxer

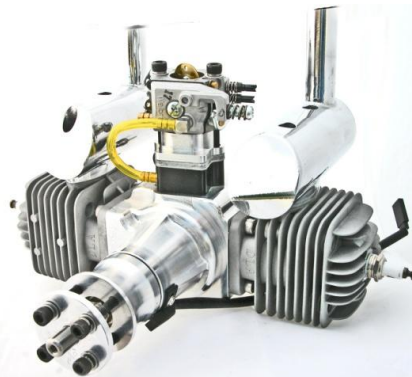

DLA 64-I2 In-Line



DLA 116cc Twin-Boxer



DLA 116cc-I2 In-line



DLA 128cc QUAD-Boxer



DLA 180cc Twin Boxer



DLA 232cc QUAD Boxer



DLA 128cc

Manufactured by: FeiaoModel, [www.dlaengine.com](http://www.dlaengine.com); USA Distributor: GOLDEN SKIES R/C  
Aircraft, Inc. [www.goldenskiesrc.com](http://www.goldenskiesrc.com) 949-378-5998

**TABLE OF CONTENTS**

• Welcome .....	3
• Legal Disclaimer / Assumption of Liability .....	4-6
• Accessories and Support Items .....	7-12
• About DLA Engines .....	13
• Technical Specifications: 32cc, 58cc, 64cc, 116cc, 116-I2, 128cc .....	13-14
• What is in the box .....	14
○ Damaged or Missing Parts .....	14-15
• Intended Engine Use .....	16
• Safety Instructions .....	16-18
• Installation in Model Aircraft .....	18-24
○ Mounting Engine to Aircraft Firewall .....	18
○ Spark Plug .....	20
○ Muffler .....	20
○ Installing Fuel (Gas) Tank, Plumbing .....	20
○ Ignition Installation and Wiring .....	20-25
○ Engine CDI/Sensor Timing .....	25
○ Cowl Ducting and Air Flow .....	25
○ Temperature Limits .....	26
• Fuel – GAS .....	26
○ Type of Gas and Oils .....	26
○ Tank Installation .....	26
○ Filters .....	26
○ Fuel Point™ .....	28
• 116-I2 , 128cc Sensor Connection / Identification .....	24
• Propeller Selection .....	24-28
○ Drilling the Propeller Bolt Holes .....	29
• Spinners and Drilling the Back Plate .....	30
• Engine Starting .....	30
○ Break-in .....	30
○ Normal Flight Operation .....	31
• Engine Maintenance .....	32-36
○ Parts Diagram .....	32-37
○ Parts List .....	33-34
• Carburetor Tuning and Care .....	39-39
• Trouble Shooting .....	40-41
• Warranty .....	43-44
○ Warranty Extension .....	43
• Dimensioned Engine Drawings and Parts Diagram .....	32-36
• Dimensioned Mounting Guide (Table 1) .....	45
• Published Specifications (Table 2) .....	46-50
• Torques: Engine Bolts .....	50
• Oil:Gas Mixture Table .....	51

**WELCOME:**

Thank you for purchasing the DLA Engine through the GOLDEN SKIES R/C Aircraft, Inc. (GS R/C) Distributorship and Distribution Channel. Welcome to the world of DLA performance and GOLDEN SKIES R/C AIRCRAFT, INC. USA service and support. We trust you will find DLA Engines and GOLDEN SKIES R/C AIRCRAFT, INC. form the perfect combination for excellent flight performance and service. It is mandatory that you, the consumer read this engine operation manual entirely and thoroughly, strictly follow all processes and procedures, most specifically the Safety Instructions and Disclaimer and Legal Liability Sections. If the consumer has any questions regarding this manual, DLA Engines and the operation thereof, please contact GOLDEN SKIES R/C AIRCRAFT, INC. at 949-378-5998 for assistance. **When the consumer breaks the seal on the DLA Operations Instructions Manual Envelope, the consumer acknowledges and agrees with, and to, the Terms and Conditions (T&Cs) listed in the Safety and Legal Disclaimer Sections of this manual.** If the consumer does not acknowledge and agree to the Terms and Conditions (**LEGAL DISCLAIMER / ASSUMPTION OF LIABILITY: Assumption of Risk Legal agreement only**), return the engine to the place of purchase for a refund. Limitations on the return and refund may apply; see the Warranty Section of the manual for limitations. Retailer Terms may differ with each individual Retailer. The consumer must register the DLA Engine warranty within seven (7) days of the original purchase date, with Golden Skies R/C Aircraft, Inc. for the warranty to apply.

If the envelope seal is already broken, such as might be experienced at a retail store, the original purchaser must assume the responsibility of acknowledging and agreeing to the Terms and Conditions of as noted above.

**LEGAL DISCLAIMER / ASSUMPTION OF LIABILITY:****Assumption of Risk Legal agreement only****Warning**

The Radio Controlled (R/C), Aircraft propelled by DLA Engines are **NOT Toys** and are potentially dangerous to property and individuals within numerous miles of your flying area. It is capable of causing substantial property damage, serious bodily harm, and possibly death if it strikes personal property or an individual.

**Consumer's Responsibility****1) Assembly and Use**

IT IS YOUR RESPONSIBILITY AND YOURS ALONE to assemble the Aircraft and DLA Engine correctly and to properly install all additional components, both included in the DLA Engine kit and/or acquired by the purchaser of this DLA Engine; to preflight test the model; to follow all Safety Instructions listed herein, and to fly ONLY in an American Model Aeronautics Association (AMA) approved flying site with the supervision and/or assistance of a fully qualified flying site instructor. The pilot of any aircraft must comply with all of the AMA's Safety Codes. The employment of common sense for safety of yourself and others is otherwise mandatory. The aircraft has a radio range of 500 (or less) feet and the pilot is directed not to exceed this distance when flying the aircraft and DLA Engine. In the event the range is exceeded, the pilot will lose control of the aircraft which could cause injury and damages to objects which the aircraft may come into contact with upon an uncontrolled landing. Do not attempt to fly any model aircraft if you have not been qualified as a solo pilot by the instructor at the AMA approved flying site. It is recommended that on any first flight of a new R/C aircraft and DLA Engine that you attain the assistance or instruction of a highly experienced R/C pilot to verify the aircraft and DLA Engine installation-construction from a safety and flight perspective. If you are just starting to fly R/C Model Aircraft of any type, consult your local Hobby Shop or write to the Academy of model Aeronautics to find an experienced instructor in your area.

**2) Assumption of the Risk**

Participation in the operation of remote controlled aircraft is voluntary. I, the purchaser, understand that the operation of remote controlled aircraft is a dangerous sport which can result in bodily injury, death, and/or damage to property for many reasons, including but not limited to airplane accidents involving third parties known and unknown to the user; equipment failure, malfunction, or misuse; weather conditions such as storms and lightning; the training, acts, omissions, recommendations or advice given by your local Hobby Shop or the Academy of model Aeronautics concerning the operation of remote controlled aircraft and related activities such as transportation to and from the site; and first-aid, emergency treatment or other services rendered to me as a user or others. I understand and acknowledge that the above list of reasons is not complete or exhaustive. I accept and hereby assume all risks of injury, death, illness or disease, or

other damage to myself, to others, or to my property which arise from participation in the referenced activities.

### 3) Release

I hereby voluntarily release, and forever discharge GOLDEN SKIES R/C AIRCRAFT, INC., a California Corporation, on its behalf and on the behalf of its successors and assigns, and each of them ("Golden Skies") and its subcontractors, and all other persons or entities associated with it, including other participants, (hereafter collectively the released parties) from all liability, claims, demands, actions or causes of action for bodily injury, death, illness, disease or damage to myself, to any participating minor child of mine, or to my property which are related to, arise out of, or are in any way connected with participation in the above referenced activities, including but not limited to those arising from any negligent or reckless acts or omissions or breach of contract of the released parties, or hidden defects in the equipment used. This release is intended to be as broad and inclusive as is permitted by California law, and shall be construed and interpreted under California law. If any portion, clause or sub clause is held invalid, I agree that the balance shall continue in full force and effect.

### 4) Maintain Proper Insurance Coverage

It is also mandatory that all R/C airplane pilots obtain adequate insurance through their own homeowner policy or a separate policy to cover liability in the event of property damage or injury to individuals or personal property. Additionally, all R/C airplane pilots must join the AMA to become secondarily insured.

Academy of Model Aeronautics <http://www.modelaircraft.org> ....

Academy of Model Aeronautics  
5151 East Memorial Drive  
Muncie, Indiana 47302-9252  
800-435-9262

### 5) Indemnification.

The user of DLA Engine products agrees to indemnify FeiaoModel and Golden Skies R/C Aircraft; and to defend Golden Skies R/C Aircraft, Inc., a California Corporation, as well as all employees, shareholders, directors, officers and agents thereof ("Golden Skies") , against any claims, lawsuits or actions arising as a result of the use of the radio controlled aircraft and DLA Engines, and shall pay for all legal expenses incurred by Golden Skies in connection with the defense of such matters, whether or not such claims are resolved without trial or other final decision and whether or not such expenses are incurred in the defense of litigation or simply incurred prior to litigation in connection with an informal claim. The obligation of the user to indemnify Golden Skies is express and unequivocal. The user is expressly obligated to indemnify Golden Skies for Golden Skies' own negligence if any, which may give rise to any claim arising in connection with the use or misuse of the aircraft and DLA Engines or components thereof



**6) No reliance**

I acknowledge that I am not relying on any oral, written, or visual representations or statements made by the released parties, including those made in released parties catalogs or other promotional material.

**7) Venue**

The Venue of any dispute that may arise out of this agreement or otherwise between the parties to which Golden Skies or its agents is a party shall be Superior Court for the State of California located in the County of Orange.

**Return Policy**

If you are not prepared to: 1) obtain adequate insurance to operate the aircraft and DLA Engine(s); 2) accept all responsibility for personal property damage and /or bodily injury, including possible death; and 3) to indemnify the engine designer, manufacturer, distributor and retailer for any liability resulting from your actions, return the complete DLA Engine kit to the point of purchase for a refund. In order to return the DLA Engine Kit, the following steps must be undertaken: DLA Engine kit must be presented in its original carton, undamaged and un-assembled not have been operated. The DLA Engine must be in the original OEM condition and suitable for resale. Purchaser must show valid purchase receipt. The DLA Engine kit must be returned to point of purchase with sixty (6) days of original purchase. A restocking fee may be charged by the retailer. All shipping and handling cost shall be borne by the consumer/purchaser. **Failure to return the DLA engine within the six (6) day period, indicated the purchaser/user is determined to agree to all the terms and conditions stipulated in the above LEGAL DISCLAIMER / ASSUMPTION OF LIABILITY section.**

**Governing Law**

Any legal action stemming from the purchase or use of the DLA Engine Products will be governed by the laws of the State of California and decided by a court of law in the State of California.

## ACCESSORIES and SUPPORT ITEMS

### FUEL POINT™:

The proprietary, GOLDEN SKIES R/C AIRCRAFT, INC. Fuel Point™ system pictured below is the most convenient and popular method of adding gas to your aircraft's fuel tank. The Fuel Point™ is installed as shown in the diagram under this manual's "Tank Installation and



Plumbing" Section, or may be downloaded from the [www.goldenskiesrc.com](http://www.goldenskiesrc.com). The Fuel Point™ provides fueling through a dedicated fuel line, thus filling the fuel tank directly and without forcing gas into the carburetor and possibly flooding the engine. It also eliminates extra plumbing elements such as a "Tee-connector" in the tank-to-carburetor fuel line. This reduces the possibility of air leaks or perhaps a total disconnection of the main engine fuel supply. The GS R/C Fuel Point™ functionality is sometimes referred to as "Fuel Dots."

**\$19.99, plus S&H from GOLDEN SKIES R/C Aircraft, Inc.**

(Prices subject to change without notice in this Operation Manual)

[www.goldenskiesrc.com](http://www.goldenskiesrc.com)

**GAS LINE:**

The fuel line must be compatible with the Gasoline-Oil mixture used for DLA Engines. GOLDEN SKIES R/C AIRCRAFT, INC. provides one of the best composite Tygon®-PVC fuel line materials. The GOLDEN SKIES R/C AIRCRAFT, INC. fuel line tends to remain more flexible over a longer time period.



Available from Golden Skies R/C Aircraft, Inc.  
[www.goldenskiesrc.com](http://www.goldenskiesrc.com)

**OIL:**

There are several good manufacturers of 2-cycle oil available. GOLDEN SKIES R/C AIRCRAFT, INC. does not, at the time of this Manual Revision (A.14) sell or distribute 2-cycle oil.

**MOUNTING (Engine) TEMPLATE:**

An optional, laser cut, engine mounting template is available from Golden Skies R/C Aircraft, Inc. The template is universal and applicable for all DLA engines addressed by this current manual revision. The GS R/C – DLA Engine mounting template is the most accurate way to locate the mounting hole-centers on the aircraft's firewall or engine box.



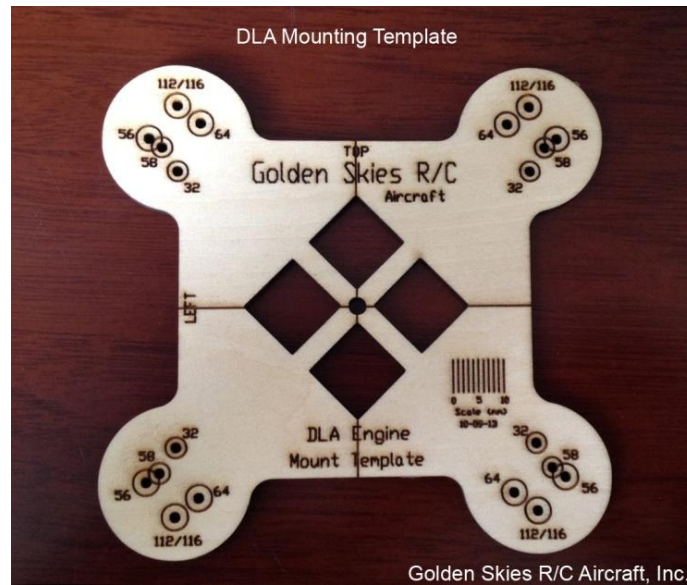

Most aircraft manufactures will provide both Vertical and Horizontal alignment lines ( $V_{c/1}$  and  $H_{c/1}$ ) on the firewall. The template has corresponding  $V_{c/1}$  and  $H_{c/1}$  lines which are aligned to those scribed on the firewall to accurately locate mounting hole. A paper mounting guide is provided at the end of this operation manual, but is not as accurate.

Laser Cut Template is available through Golden Skies R/C Aircraft, Inc.  
[www.goldenskiesrc.com](http://www.goldenskiesrc.com)

PN: 03180-50005-A (\$9.99)

#### DRILL BIT GUIDE – (for Propeller Bolts)

Specifically engineered **D**rill **B**it **G**uides (DBG) for each DLA Engine is the preferred and most accurate method for locating and drilling the holes in the propeller hub for the Propeller Bolts.

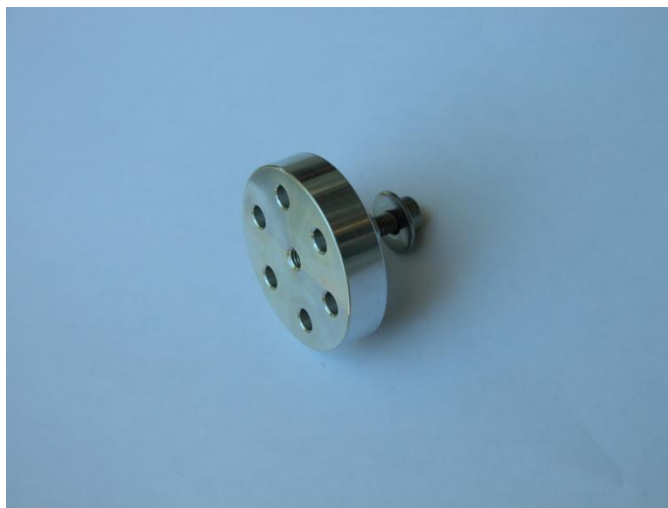

Shown above is the DBG for the DLA 32cc gas engine. The centering tab on the back of the DBG is inserted in the prop's crankshaft hole and the engraved arrows, aligns with the prop's axis. The first hole is drilled, using the specified drill bit (see Prop-drill bits below) and then the alignment/anchoring pin is inserted through the DBG and propeller to secure the DBG while the remaining holes are drilled.

The GS R/C – DLA Drill Bit Guide is available through [www.goldenskiesrc.com](http://www.goldenskiesrc.com)

### Drill Bits:

GOLDEN SKIES R/C AIRCRAFT, INC. stocks metric drill bits in the precise sizes to match the specific propeller bolts for each of the DLA Engines:

DLA 32cc	4.2 mm	GS R/C #: 03180-50001 (\$20.99)
DLA 58cc	5.2 mm	GS R/C #: 03180-50002 (\$20.99)
DLA 64cc	5.2 mm	GS R/C #: 03180-50002 (\$20.99)
DLA116cc	5.2 mm	GS R/C #: 03180-50002 (\$20.99)

All DLA Engines have a ten (10) mm crankshaft diameter. The propeller's crankshaft hole should be sized to ten (10) mm. The appropriate drill bit is:

10 mm x - 135°      GS R/C # 01380-50003

### Propeller Bolts:

GOLDEN SKIES R/C AIRCRAFT, INC. stocks the proper Propeller Bolts for each of the DLA Engines. It is important to use only the specified propeller bolts for proper diameter, thread-pitch, strength and operation.

The specified prop-Bolts are:

DLA 32cc	PN: 01380-00102
DLA 58cc	PN: 01380-00202
DLA 64cc	PN: 01380-00302
DLA 116 / 116-I2cc	PN: 01380-00402
DLA 128cc	PN: 01380-00502

### PROPELLERS:

The propeller brand selection is somewhat a personal preference and is generally guided by personal experience and the type of flying desired. Several good propeller manufacturers are available. Some of the known propeller manufacturers are:

- 1) Menz
- 2) Mejzlk
- 3) Beila
- 4) APC
- 5) Xoar
- 6) NX
- 7) Falcon
- 8) Sail

**SPINNERS:**

A sturdy, light weight spinner is best, but they tend to be rather expensive. GOLDEN SKIES R/C AIRCRAFT, INC. offers lower cost spinners. Please refer to the GOLDEN SKIES R/C AIRCRAFT, INC. website for spinner selections from two (2) inch to four (4) inch diameter.

[www.goldenskiesrc.com/Product\\_page\\_Spinners.html](http://www.goldenskiesrc.com/Product_page_Spinners.html)



The prop-nut shown on the lower left is not required for DLA Engines; however, you will still secure the spinner using the “Spinner-bolt” shown on the lower right. The tip of the engine’s crankshaft is drilled and tapped for a 5.0 mm x 0.8 mm bolt. The length of the spinner-bolt will depend upon the spinner size.

**Spinner Bolts:** GS R/C has a stock of spinner-bolts in various lengths. Visit the Golden Skies R/C Aircraft website to purchase. [www.goldenskiesrc.com](http://www.goldenskiesrc.com)

**IGNITION SWITCH:**

An Ignition “**Kill**” Switch (IKS) is required for all DLA Engine / Ignition Installations. Refer to the installation procedures and diagrams in the “Ignition Installation and Wiring” Section. GOLDEN SKIES R/C AIRCRAFT, INC. offers the switches that are most commonly used for the IKS:

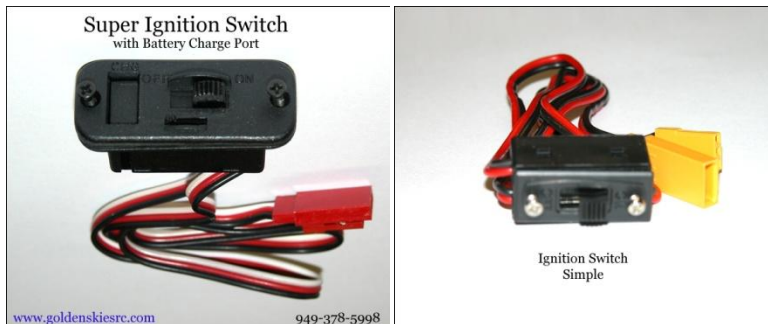
**IGNITION BATTERY:**

All DLA Engine Ignitions operate within a 6.6 V DC to 8.4 V DC range. A-123-Series, LiPo are commonly used. However, good quality **Nickel-Metal-Hydride** (NiMH) battery, in a six- (6) series configuration, is also adequate. An 1,200 mAh battery is sufficient. However, a 2,100 mAh battery is recommended for the Dual Ignition engines. Check the Golden Skies R/C Aircraft website for battery selections. The CDI will not operate under 6.3 VDC and damage to the CDI may occur if the CDI supply voltage is less than 6.0 VDC.

[www.goldenskiesrc.com](http://www.goldenskiesrc.com)

**BOLT SET (Engine):**

Complete DLA Engine bolt sets are available for each DLA engine. The Engine bolt set includes Mounting bolts, prop-bolts, muffler bolts, and appropriate flat-washers and lock-washers.

- |                |                 |
|----------------|-----------------|
| ➤ DLA 32cc     | PN: 01380-00103 |
| ➤ DLA 58cc     | PN: 01380-00203 |
| ➤ DLA 64cc     | PN: 01380-00303 |
| ➤ DLA 64-I2    | PN: 03180-03146 |
| ➤ DLA 116cc    | PN: 01380-00403 |
| ➤ DLA 116-I2cc | PN: 03180-01412 |
| ➤ DLA 128cc    | PN: 03180-01624 |
| ➤ DLA 180cc    | PN: 03180-00948 |
| ➤ DLA 232cc    | PN: 03180-02034 |

-----**END OF ACCESSORIES**-----

**ABOUT DLA ENGINES:**

The DLA Engine has been specifically designed, developed and manufactured from proprietary components for larger (32cc and up) size Model Aircraft. The DLA series of engines are very powerful, exceptionally light weight for its class, easy to operate and adjust. DLA engines should provide years of satisfactory performance, if maintained properly. DLA Engines are manufactured by FeiaoModel in China. See warranty.

**Technical Specifications:** (See Table 2 for more comprehensive list of Specifications)

**DLA - 32cc GAS ENGINE**

➤	Displacement:	32cc (1.95 in <sup>3</sup> )
➤	Horsepower:	3.8 Hp @ 8,200 rpm
➤	Idle:	1,700 rpm
➤	Static Thrust:	19.4 pounds (Pulling Force)*
➤	Props:	18x8, 18x10, 19x8, 20x8
➤	Compression:	7.6 : 1
➤	Spark Plug:	CM6-Special, Iridium
➤	Cyl. Dia / Stroke:	37 / 30 mm (1.46" / 1.18")
➤	Gas:Oil Ratio:	45:1 Typical (Flying)
➤	Weight:	44.6 oz (2.79 lb) (All Components)

**DLA - 58cc GAS ENGINE**

➤	Displacement:	58cc (3.42 in <sup>3</sup> )
➤	Horsepower:	6.0 Hp @ 8,500 rpm
➤	Idle:	1,400 rpm
➤	Static Thrust:	33.1 pounds (Pulling Force)*
➤	Props:	22 x 10, 23 x 8/10, 24 x 8
➤	Compression:	7.8 : 1
➤	Spark Plug:	CM6-Special, Iridium
➤	Cyl. Dia / Stroke:	46 / 35 mm (1.77" / 1.38")
➤	Gas:Oil Ratio:	45:1 Typical (Flying_
➤	Weight:	63.1 oz (3.94 lbs) (All Components)

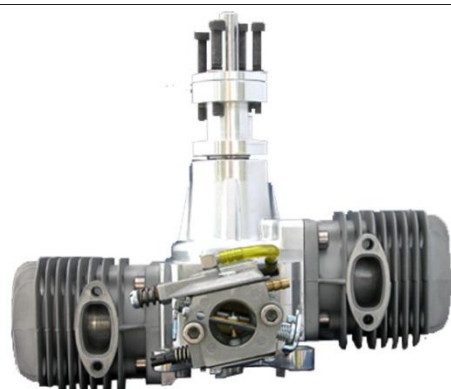
**DLA 64cc Gas Engine**

➤	Displacement:	64cc (~3.97 in <sup>3</sup> )
➤	Horsepower:	7.2 @ 8,500 rpm
➤	Idle:	1,400 rpm'
➤	Static Thrust:	34.4 pounds -Pulling Force
➤	Props:	22x10, 23x8 /10, 24x8
➤	Compression:	7.8 : 1
➤	Spark Plug:	CM6-Special, Iridium
➤	Cyl. Dia / Stroke:	37 / 30 mm (1.46" / 1.18")
➤	Gas:Oil Ratio:	45:1 Typical (Flying)
➤	Weight:	72.4 oz (4.5 lbs) (All Components)





## DLA 116cc Twin Boxer

- Displacement: 116cc (6.83 in<sup>3</sup>)
- Horsepower: 11.8 @ 7500 rpm
- Idle: 1300 rpm
- Static Thrust: 59.9 pounds - pulling Force
- Props: 26 x 10/12, 27 x 10, 28 x 10
- Compression: 7.8 : 1
- Spark Plug: CM6-Special, Iridium
- Cyl. Dia / Stroke: 46 / 35 mm (1.78" / 1.38")
- Gas:Oil Ratio: 45:1 Typical (Flying)
- Weight: 107.6oz (6.72 lbs) (All Components)



## DLA 116cc In-Line Twin

- Displacement: 116cc (6.83 in<sup>3</sup>)
- Horsepower: 11.8 @ 7,500 rpm
- Idle: 1,300 rpm
- Static Thrust: 59.9 pounds (Pulling Force)
- Props: 26 x 10/12, 27 x 10, 28 x 10
- Compression: 7.8 : 1
- Spark Plugs: CM6 – Special, Iridium
- Cyl. Dia / Stroke: 46 / 35 mm (1.78: / 1.38")
- Gas: Oil Ratio: 45 : 1 Typical (Flying)
- Weight: 122.1 oz (7.63 lbs) OZ (All Components)

## DLA 128cc QUAD BOXER



DLA 128cc

- Displacement: 128cc (7.94 in<sup>3</sup>)
- Horsepower: 13 hp
- Idle: 1,250 rpm
- Static Thrust: 61 pounds @ 100m (~328 ft)
- Props: 27 x 10/12, 28 x 10, 29 x 12
- Compression: 7.8 :1
- Sparkplugs: CM6 – Special, Iridium
- Cyl. Dia / Stroke: 37 / 30 mm (1.46" / 1.18")
- Gas : Oil 45 : 1 Typical (Flying)
- Weight: 148.5 oz (9.29 lbs) (All Components)

\*Typical Value, User Thrust will vary dependent upon, Propeller, rpm and numerous other factors.

**ITEMS INCLUDED IN THE RETAIL ENGINE BOX WHEN SHIPPED:**

The following items are in the retail box. Any missing or damaged parts must be reported to GOLDEN SKIES R/C AIRCRAFT, INC. within seven (7) days of the original purchase date to make a claim for replacement(s):

1. Engine, 1-each
  - a. Sparkplug, 1-ea DLA 32, 58, and 2-ea DLA 64cc & 116cc, 4-ea 128 QUAD
  - b. Prop-Washer, 1-each
  - c. Prop Bolts, 4-each, DLA 32, 58, 64cc and 6-each DLA 116cc, 128 QUAD
  - d. Ignition Pick-up Sensor and Wire Lead, (2-ea on 64, 116cc, 128QUAD eng.)
  - e. Carburetor(s)
2. Muffler(s)
  - a. Gasket, 1-each DLA 32, 58, and 2-each DLA 64cc, 116cc, 4-ea 128cc QUAD
  - b. Mounting bolts, 2 each DLA 32, 58, and 4 each DLA 64cc, 116cc
3. Ignition, 1-each on 32, 58, 64, 116 Twin, 2-ea on 116-IL & 128 QUAD
  - a. Silicon Pick-up Wire Wrap Protector and connector Safety Clamps
4. Mounts, Engine (Stand-offs), 4-each, if applicable
  - a. Mounting bolts, 8-each for DLA32, 58, 64cc and 4-each for DLA 116, 128cc
5. Operating Manual on website (visit [www.goldenskiesrc.com](http://www.goldenskiesrc.com) for the most current Revision)

**INTENDED ENGINE USE:**

DLA, 2-cycle, Gasoline Engines are designed **exclusively** for installation in and as the propulsion system for Radio Controlled Model Aircraft. Any other use is prohibited. Installation is described in this Operations Manual (PN: 03180-1000, Rev. *See footnote*). It is the responsibility of the consumer to install the engine properly using the installation guidelines of this manual as a minimum standard.

**SAFETY INSTRUCTIONS:**

**DLA Gasoline Engines are not toys and can cause serious injury or death when not used properly and with extreme caution at all times. Adherence to the Safety Instructions, here-in, as a minimum requirement, is absolutely mandatory.** Read thoroughly, and become intimately familiar with all safety instructions. **Initial each line item to indicate you have read and understand the instruction.** If you do not understand any or all of the Safety Instruction line items, re-read until you do or consult with the **American Model Aeronautics Association**. Further, read the entire DLA Engine Operating Manual and be sure you are totally familiar and understand each and every item. **Learn completely the engine's application, limitations and possible hazards. Review the Safety Instructions monthly.**

1. **OPERATE IN WELL VENTILATED AREAS:** Make sure the area of operation is well ventilated. Never operate the engine in an enclosed area.
2. **INSPECT ALL BOLT FOR SECURITY:** Inspect the engine bolts and all engine components prior to starting and operating the engine:
  - a. Check the Security of the prop-bolts.
  - b. Check the Security of the engine mount bolts.
  - c. Check the Security of all gas line connections.
  - d. Check to see that the ignition and ignition battery are firmly secured to the airframe.
  - e. Confirm the integrity of and proper connection of all ignition wiring.
  - f. Check to see that the Muffler is securely attached to the engine.
3. **USE ENGINE KILL SWITCH: Always install a manual ignition on-off or engine "kill" switch on the outside of the aircraft frame and well back of the engine propeller.**
  - a. A remotely operated "kill" switch, one that is controlled by the RC Transmitter in addition to the manual Kill Switch may also be advisable.
4. **NEVER OPERATE ENGINE ALONE:** Always, have a second person restrain the aircraft when starting the engine.
5. **STAY CLEAR OF ROTATING PROPELLER:** Do not lean over, stand in front of or directly to the side of an operating engine. Do not get within two feet of a rotating propeller and do not reach toward or point toward the rotating propeller.
6. **POINT AIRCRAFT AWAY FROM OTHERS:** Be sure the aircraft is pointed away from all others when starting.
7. **KEEP SPECTATORS AWAY:** Keep all spectators at least thirty (30) feet away from the engine and aircraft when preparing to start and operating the engine.
8. **WEAR PROPER APPAREL:** Do not wear loose clothing, gloves, neckties, jewelry, neck straps, loose shoe strings or any other item that could become entangled in the engine's propeller. The above list may not be all inclusive.
9. **DO NOT ADJUST ENGINE WHILE RUNNING:** Never try to fix, alter or adjust anything on the aircraft or engine while the propeller is rotating. Always stop the engine from running (operating) when making adjustment to the engine.
10. **WEAR EYE PROTECTION:** Always wear eye protection when operating the engine. A full face shield is preferred.
11. **USE CORRECT PROPELLER SIZE:** Always use the correct size propeller (see Propeller Selection).
  - a. **Be sure the propeller is completely balanced.**
  - b. Check the Prop Bolts for security and always use thread locking material on each Propeller Bolt.
12. **USE FACTORY FURNISHED ENGINE BOLTS:** Use the proper length propeller bolts:
 

a. DLA 32cc	4.0 mm x 0.7 mm	– 35 mm Steel Bolts
b. DLA 58cc	5.0 mm x 0.8 mm	-- 40 mm Steel Bolts
c. DLA 64cc	5.0 mm x 0.8 mm	-- 40 mm Steel Bolts
d. DLA 116cc	5.0 mm x 0.8 mm	– 50 mm Steel Bolts
13. **ENGINE FUEL IS HIGHLY FLAMMABLE AND DANGEROUS: The Gasoline and Oil: fuel mixture, is highly flammable and dangerous.** Keep the engine fuel container (Gasoline and Oil) in a safe place and at least fifteen (15) away from the aircraft. Keep the Fuel away from sparks, open flame or anything else that could accidentally ignite the fuel. Keep fuel away from children. DO NOT SMOKE within twenty (20) feet of the engine fuel. **Have a fire extinguisher on hand.**

14. **OPERATING ENVIRONMENT:** Do not operate the engine in the vicinity of loose materials of any kind, including dirt, sand, gravel, grass (that can reach the propeller), strings, power cords, and anything else that can be blown by the propeller's "prop-wash" or get caught in, sucked into, or reach the operating propeller. The list above is not all inclusive.
15. **BALANCE SPINNER:** Always be sure that the spinner is balanced and installed according to the spinner manufacturer's instructions. Do not allow the edges of the spinner's propeller cut-outs to touch the propeller.
16. **DAMAGED PROPELLER OR SPINNER:** Never use a damaged propeller or spinner: Ex: one that has come into contact with the ground or other objects, or has been involved in a crash. Do not use a propeller that is split, cracked, pitted or has any other flaws or damage. Follow all Propeller Manufacturer's instructions.
17. **NEVER THROW ANY ITEM INTO SPINNING PROPELLER:** Never attempt to stop the propeller by injecting or throwing anything into a rotating propeller.
18. **USE SPECIFIED ENGINE FUEL LINE:** Use only approved fuel line that is suitable for gasoline and oil.
19. **ENGINE GETS HOT:** The engine is extremely hot after operation. Do not touch the engine after running. Allow ample time for the engine to cool off prior to touching it.
20. **DO NOT REFUEL WHEN ENGINE IS HOT:** Never refuel the aircraft while the engine is still hot. Allow the engine to cool to a comfortable "hand-touchable" temperature before refueling.
21. **REMOVE FUEL BEFORE TRANSPORTING:** Remove all fuel from the aircraft fuel tank and engine prior to transporting the aircraft.
22. **USE SPECIFIED ENGINE OIL:** Use high-quality, 2-cycle oil when mixing with the gasoline.
23. **USE NON-METALLIC THROTTLE PUSH-RODS:** The throttle's push-rod and clevises should be non-metallic.
24. **FILTER FUEL-GAS:** Always filter the engine's fuel when filling the aircraft's fuel tank.
25. **COMPONENT LOCATIONS:** Mount the ignition battery, kill-switch and throttle servo at least six to twelve (6 - 12) inches to the rear of the aircraft firewall.
26. **KILL SWITCH OPERATION:** Stay clear of the propeller when switching the Kill-switch on or off. Accidental ignition may occur and start the engine.
27. **COWL AIR FLOW:** Provide for proper venting of the cowl to keep the engine cool while operating.
28. **CLEANLINESS:** Keep all engine surfaces clean and free from gasoline, oil or other debris.
29. **SPARKPLUG REMOVED:** Do not rotate the propeller with the ignition switched on, while the sparkplug has been removed. Irreversible damage to the ignition system will occur.
30. **LEAN GAS-MIXTURE DAMAGE:** Do not run the engine with a "LEAN" gas mixture. The engine will overheat and permanent damage will occur.
31. **FIRE EXTINGUISHER:** Always have a portable fire extinguisher on hand and readily available. Consult with your local fire authority for the best type with respect to your flying environment.
32. **NEVER START BY HAND PROPPING, ALWAYS USE AN ELECTRIC STARTER**

## ENGINE INSTALLATION IN MODEL AIRCRAFT

### Mount Engine to Model Aircraft Firewall:

Prior to mounting or re-mounting any DLA engine onto the aircraft, review all safety instructions, check to be sure all engine bolts, plugs, etc. are securely in place. Check the engine thoroughly for any damage, cracks, or unusual wear.

1. Install the Silicon Wire-wrap Protector over the ignition pick-up wire. Remove any excess silicon protector.
2. Mount the engine to the aircraft firewall.
  - a. The firewall must be at least  $3/8"$  (~9.5 mm) thick and perfectly flat.
  - b. There are three methods for locating the mounting-hole centers on the firewall:
    - i. **PREFERRED:** Use the GS R/C – DLA Engine Mount Template.
    - ii. **ACCEPTABLE:** Use the paper template at the end of this manual
      1. Check the dimensions on the paper template by measuring between the appropriate hole-center locations and confirm they are as specified either on the paper template or per the dimensions on Table 1. (Paper can shrink and expand and printing may, and often does vary dimensionally.)
    - iii. **LEAST PREFERRED:** Manually measure the hole locations from the  $V_{c/1}$  and  $H_{c/1}$  and mark on the firewall as per the engine mount dimensions given in Table 1.
3. Using the template, align the respective  $V_{c/1}$  and  $H_{c/1}$  on the GS R/C – DLA Engine template or the paper template with the corresponding  $V_{c/1}$  and  $H_{c/1}$  on the aircraft firewall.
  - a. **NOTE:** Follow the alignment procedures described in the model aircraft assembly manual. The aircraft's manual instructions should allow for any right or down thrust that may be built into the aircraft's firewall.
  - b. **NOTE:** **The objective is to have the engine's crankshaft be perfectly aligned with the aircraft thrust-line at the point where the crankshaft exits the aircraft's cowl.**
4. When the template is aligned properly to the firewall, mark the four (4) mount holes, center locations with a center punch or an awl. Center punch the awl marks if needed.
5. Drill the engine firewall, mounting holes, using a drill-bit as follows:
  - a. DLA 32, 58, 64, 116 cc      PN: 03180-50000, 5.2 mm OD, 135°
6. Install the DLA stand-offs (included), or use stand-offs of a length to specifically match the requirements of your model aircraft dimensions. (THE WARRANTY DOES NOT



- COVER NON-DLA STAND-OFFS OR DAMAGE CAUSE TO THE DLA ENGINE AS A RESULT OF USING NON-DLA STAND-OFFS.)
- a. The cut “squared-off” end of the DLA stand-off attaches to the engine.
  - b. If additional stand-off length is needed, extra spacers should be placed between the firewall and the DLA-Stand-off. Extra spacer length such not exceed 10% of the standoff length. The opposite ends of any spacer must be perfectly parallel, flat and the diameter should not be less than the DLA Stand-off, flared base.
  - c. Mount the stand-offs to the firewall and leave the bolts slightly loose for the moment. Use washers between the bolt-head or nuts and the firewall backside, the larger in diameter the better.....within reason.
  - d. Mount the engine to stand-offs using the 4 ea bolts:
    - i. 5.0 mm x 0.8 mm – 20 mm (DLA 32, 58, 64cc)
    - ii. 5.0 mm x 0.8 mm – 50mm (DLA 116, 128cc)
7. Check the alignment of the engine, with the cowl mounted, to determine that the crankshaft is exiting the cowl properly. (See Model Aircraft Assembly Manual for Details.)
8. Adjust as necessary and secure all bolts.
- a. **Use lock washers and thread locking compound on all threads.**
9. The supplied stand-offs set the minimum distance between engine’s carburetor and the firewall. If you use non-DLA Stand-offs, do not decrease this distance. If you cannot maintain this minimum distance, you may want to consider cutting a hole in the firewall, directly in line with the carburetor with a diameter approximately equal the diameter of the carburetor’s intake. **DO NOT COMPROMISE THE INTEGRITY OR STRENGTH OF THE FIREWALL. If you have questions about altering the firewall, check with the model aircraft’s manufacturer or distributor.**
10. For the DLA 116cc, where the carburetor generally points downward, there should be at least 1 to 1-1/2” (~38 mm) between the bottom of the carburetor and the cowl.
11. GENERALLY, THE CARBURETOR INTAKE SHOULD BE SITUATED IN “STILL AIR”. Swirling or turbulent air in or around the carburetor intake can significantly disrupt the carburetor operation and the cause poor and/or erratic engine performance. How the air behaves on the ground and in flight is always different and you may need to control the airflow in and around the carburetor intake.
12. Take note of the carburetor’s High and Low needle valve locations. To avoid having to remove the cowl for adjustments, you may want to consider making a hole(s) in the cowl to access these mixture adjustments. With the cowl on or off, engine performance often differs. Final adjustments with the cowl in place is often more desirable.
13. COWL Vents and Air Flow: Be sure that the cowl openings are sufficient to provide adequate airflow across the DLA cylinder head fins. Generally, the “rule-of-thumb” is to have the air exit holes to be three (3) times the size of the air intake. If the air intake is too big, sufficient air flow may not be directed over the engine’s cooling fins. In such cases, some air flow directivity may be required, through the use of “air dams” or vanes.

**SPARK PLUG:**

Install the Special CM6-Special, Iridium Sparkplug supplied in the engine's cylinder head. Take care not to cross-thread the plug. The proper torque for the plug is: 7.5 -> 8.0 ft-lbs (~96 in-lbs, or ~10.2 Nm) for all DLA Engines. The typical spark-plug gap is: 0.018 -> 0.02 inches. The gap is set by the manufacturer, attempting to adjust the gap can damage the hard iridium metal.

**MUFFLER INSTALLATION:**

Attach the DLA muffler to the engine using the two (2) supplied, 5.0 mm x 0.8 mm – 16mm Socket Head bolts and gasket supplied. No gasket sealant is required. The DLA 64 & 116cc engine has two (2) mufflers and therefore, four (4) each attachment bolts and two (2) gaskets. The 128cc Quad has eight (8) bolts. Torque each bolt to 60 -> 65 in-lbs (6.7 -> 7.3 N\*m). Over torque can strip the threads. **Check bolt tightness after every three or four flights.** (See: torques on page 50)

Follow the model aircraft's assembly manual for providing exit holes for the muffler stacks.

**IGNITION INSTALLATION AND WIRING:**

All DLA Engine ignition wiring configurations are basically identical. The exception is that the DLA 64 and 116cc engines have two (2) Ignition or Sparkplug wires running from the Ignition Module to the two (2) individual Sparkplugs.

Install the ignition in the forward part of the fuselage and isolate it from the airframe with foam rubber at least 1/2" thick. Secure in place with Velcro® or other like material. Be sure the location allows all the wiring to reach the intended end points. The ignition wiring diagram is shown below.

**NOTE:** *When referring to the "SEX" of the connector, it is the connector PINS and Sockets that determine the sex and not the shape of the connector housing.* So, always look at the pins or sockets. Manual notation is: Male (M) and Female (F). Generally, the sex of the Ignition's and the Engine's connectors are such that they only go together in the correct way.

The step-by-step procedure for the wiring installation is as follows:

1. **Step 1:** Install the Ignition Kill Switch (IKS) through the side of the fuselage, at a location easily accessible and safely away from the engine's propeller.
  - a. A battery charger connection is built into the "Super Ignition Switch".
  - b. **Do not charge a LiPo battery while the battery is in the aircraft. Always remove the LiPo battery and charge in a fire proof, safe location.**
2. **Step 2:** Connect the IKS "Power Switch Wire" to the "Ignition's Power Wire". The Ignition Power Wire is a two (2) wire lead (Red "+" and Black "-"). An adapter is provided with the engine if needed. Add a safety clip over the connectors. (Note the optional remote Kill Switch.)

3. **Step 3:** Wrap the small Spiral-Wire-Protection covering around the engine's pick-up sensor wire, from the sensor to the connector. Cut off any excess. Then wrap the Ignition's Pickup sensor wire and cut off any excess.
4. **Step 4:** Connect the Ignition's Timing Pickup wire (F) to the Engine's Pickup Sensor Wire (M).
5. **Step 5:** Wrap the large Silicon-Wire-Protection covering over the Ignition's Sparkplug wire.
  - a. Take care not to damage the braided wire sleeve on the sparkplug wire. This is both an EMI shield and the electrical "return path".
6. **Step 6:** Connect the optional tachometer in a location that can be seen from outside of the aircraft, and connect the wires together.
7. **Step 7:** Push the sparkplug cap over the sparkplug until it "snaps" into place. Check to see that the cap cannot be removed with a light pulling force. Be sure it is firmly seated.
8. **Step 8:** Double check that all connections are secure and that the **electrical polarity orientation is correct**. That is, Red wire to Red wire, black to black and white to white.
9. **Step 9:** Secure all connections with the connector clips provided.
  - a. Heat shrink tubing (not supplied) may also be placed over the connections and used to prevent the connector from coming apart.
10. **Step 10:** **Be sure the IKS is in the OFF-POSITION**. Connect the Battery Lead (2-wires) to the IKS. **Be sure RED wire goes to RED wire and Black to Black. The CDI Battery Voltage is: 6.4 to 8.4 VDC**. Operating the CDI at 6.0VDC or less may result in damage to the CDI.
11. **Step 11:** Dress all wiring such that minimal vibration is present but not so secure as to cause abrasion.

**WARNING:** Any time the IKS is in the "ON" position, the ignition is active (armed) and the engines could be started with any movement of the propeller.

**NOTE:** The torque on the sparkplug is: 7.5 -> 8.5 ft-lbs.

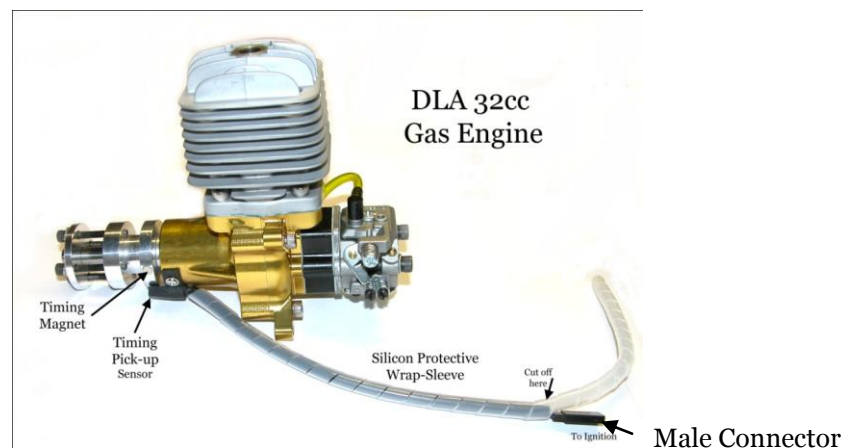

CDI Voltage:

6.4 – 8.4 VDC

# DLA ENGINE OPERATING-INSTRUCTION MANUAL

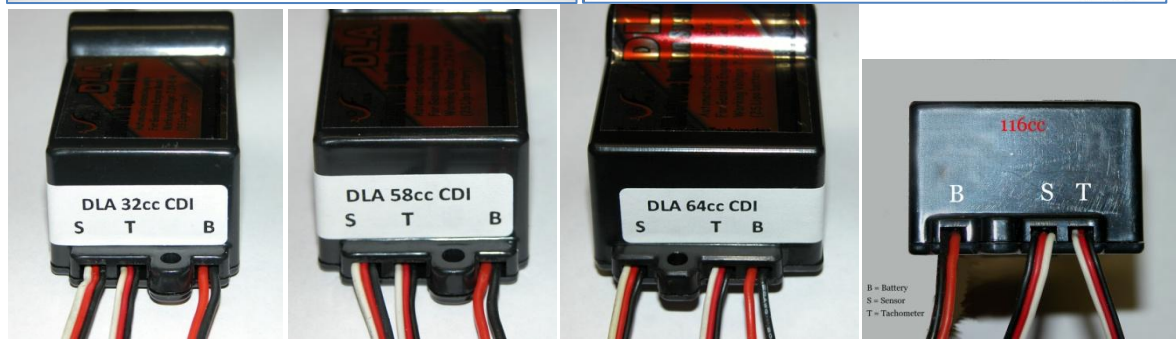
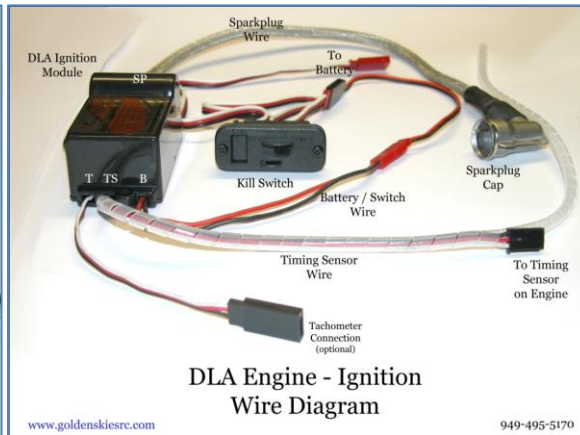
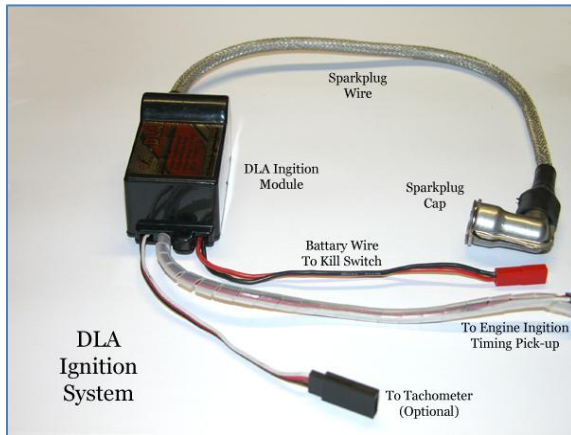

The above CD Ignition pictures are the most current configurations, older CDI's may vary; check the connector sex for correct "Sensor, Tachometer & Battery" wiring. This wiring arrangement may vary. **Note: The tachometer wire gauge is slightly less than the Sensor wire gauge. DO NOT USE AN RCEXL TACHOMETER WITH DLA CD IGNITIONS.**

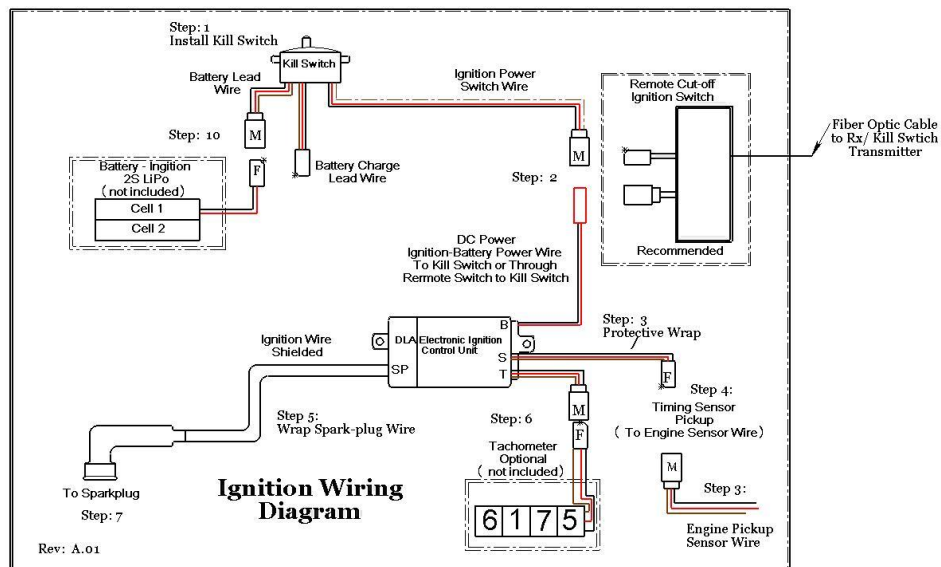

## IGNITION TIMING, SENSOR: (How to set the timing sensor)

The sensor timing is set at the factory to  $\sim 30^\circ$  before TDC, and you should not have to be reset it. If you do not have the proper tools and experience with setting the timing, you may be better off leaving it alone. Never-the-less, depending upon several factors including: altitude, temperature, ultimate tuning for specific application such as racing, you may want to adjust the timing. Be sure to check the sensor screws to be sure they are tight and mark the sensor edges on the crankcase with a felt pen or scribe for reference before proceeding. This manual will offer only limited timing information and if you feel you need to adjust the time, please contact GS R/C and we may be able to provide more definitive information, depending on your situation.

The sensor timing is set in degrees ( $^\circ$ ) of crankshaft rotation (*counter clock-wise*), before **T**op-**D**ead-**C**enter (TDC). TDC is when the piston is at the furthest travel toward the top of the cylinder. A magnet, which is pressed into the prop-hub, follows the top of the piston and will typically align with a “landmark” on the crankcase at TDC. As the magnet passes under the sensor, it stimulates the sensor and sensor generates an electrical pulse which the CDI uses to create a spark in the sparkplug. The sensor’s electric pulse is represented in the diagram below. The pulse can be several degrees wide; so, it is important to set the timing on the negative edge of the pulse which is position where the magnet is “leaving” the sensor.

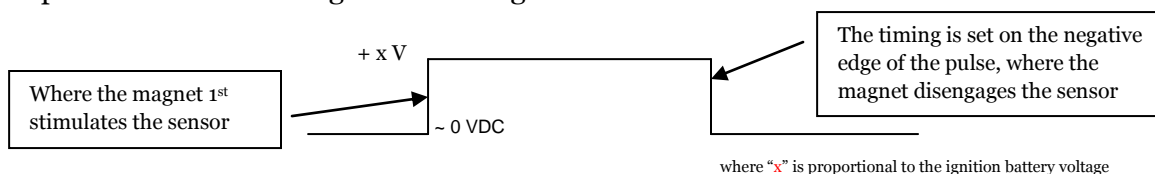

The timing pulse occurs on the “white-wire”, where the Red = Power, and the Black = Ground-return. Rotate the prop-hub to the position where the piston is at TDC.

The 116cc, In-line and 128cc QUAD engines have two (2) sensors and two (2) CDI’s and each must be set separately, see table below. **The In-line and the QUAD sensor settings are  $180^\circ$  apart and each sensor is set specifically for the cylinder or cylinder bank that particular sensor is controlling.**

Engine Disp.	Timing before TDC	1 <sup>st</sup> Cylinder of Bank	2 <sup>nd</sup> Cylinder or Bank
32cc	28 - 32 $^\circ$ (30 $^\circ$ Typ)		
58cc	28 - 32 $^\circ$ (30 $^\circ$ Typ)		
64cc	28 - 32 $^\circ$ (30 $^\circ$ Typ)		
116cc Twin	28 - 32 $^\circ$ (30 $^\circ$ Typ)		
116cc IL		30 $^\circ$ Typ	28-29 $^\circ$
128cc QUAD		30 $^\circ$ Typ	28-29 $^\circ$
Note: Increasing the angle is said to be “ <i>Advancing</i> ” the time and decreasing the angle is said to be “ <i>Retarding</i> ” the timing.			

**With the In-Line and the QUAD engines, it is often advisable to set the 2<sup>nd</sup> cylinder (rear) or 2<sup>nd</sup> cylinder bank, 1-3 $^\circ$  retarded with respect to the 1<sup>st</sup> cylinder/bank.** This is done to help keep the 2<sup>nd</sup> cylinder/bank cool, as these cylinders are in the “hot-air shadow” of the front cylinder/bank. Special consideration for cooling the 2<sup>nd</sup> cylinder/bank (rear) should always be addressed. (See Cowl Ducting and Air Flow below.)



**64-I2, 116-I2m, 128, 232 QUAD: CONNECTING THE TWO (2), CDIs TO THE PROPER SENSOR**

The 64-I2 & 116-I2 In-line and the 128cc & 232cc QUAD have two (2) sensors and two (2) ignitions to drive the front and rear cylinders separately. The paired combinations of one each sensor and one ignition is dedicated specifically to the front or rear cylinder bank(s). Therefore, you must connect the front cylinder's sensor/ignition to the front cylinder(s) and the rear sensor/ignition to the rear cylinder(s). The 64-I2 & 116-I2 and 128cc & 232cc sensors are typically mark with an "F" or "R" to denote which sensor goes with the designated cylinder(s) bank (front or rear). See pictures below.

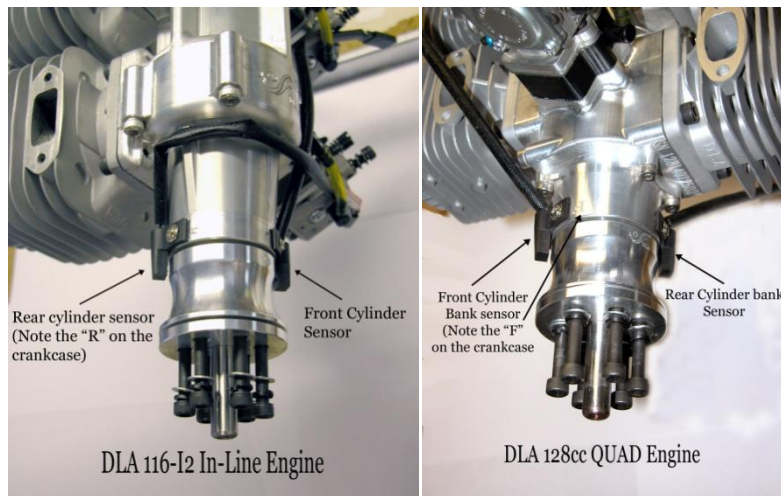

If the crankcase should not be marked with an "F" or "R", then refer to the pictures for the correct sensor identification. Another way to identify the front sensor is to rotate the crankshaft so that the front cylinder-piston is at top-dead-center (TDC<sub>f</sub>). Note the location of the timing magnet on the prop-hub. The magnet will be located just CCW from the front sensor. The magnet will be ~28-30° CCW relative to the front sensor. **For an optional method of connecting the dual CDIs to a single battery, refer to Appendix B at the end of this manual.**

**CAUTIONS:**

1. Advancing the timing causes the engine to run hotter. (See Temperature Limits)
2. Advancing the timing typically increases the power.... to a limit.
3. Advancing the timing, may make the engine harder and more dangerous to start.
4. Advancing the timing is harder on the engine and advancing beyond 32° voids the warranty.

**COWL DUCTING and AIR FLOW**

Be sure that the cowl openings are sufficient to provide adequate airflow across the DLA cylinder head's, cooling fins. Generally, the "rule-of-thumb" is to have the air exit holes to be three (3) times the size of the air intake. If the air intake is too big, sufficient air flow may not be directed

over the engine's cooling fins. In such a case, some air flow directivity may be required, through the use of "air dams" or vanes.

**The QUAD and the In-Line engines require special air flow considerations.** Since both types have one or more rear cylinders that are in the "hot-air shadow" of the forward cylinder(s), it is the pilot's responsibility to provide adequate cool air flowing across the rear cylinders.

In the case of the QUAD, one typically directs the airflow from the cowl intake to an area (chamber) above the cylinder heads and then directs the air to flow downward across both forward and rear heads. (See diagram)

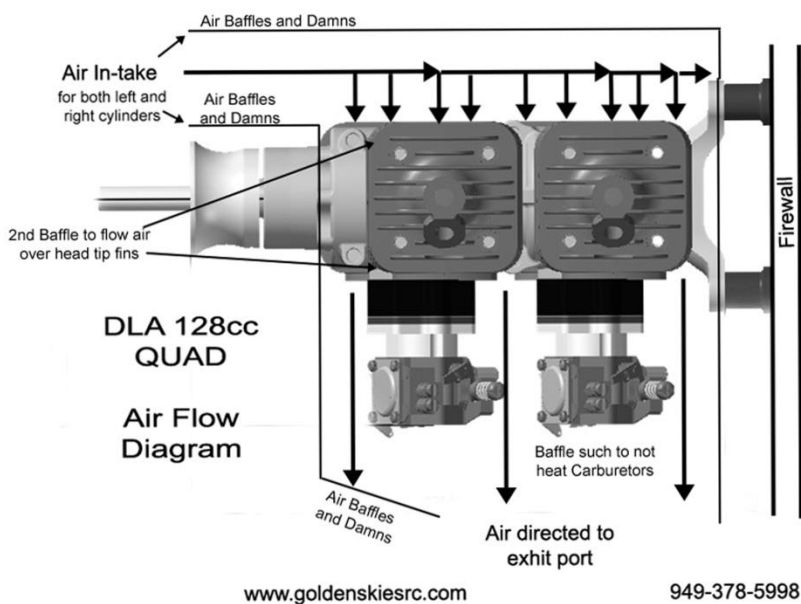

The same airflow principals would also apply to the 116cc In-Line engine.

### TEMPERATURE, ENGINE, LIMITS:

**The engine head temperature should never be allowed to reach or exceed 120° C (248° F) and the crankcase should be restricted to 70° C (158° F).** Here is where some temperature measurements and perhaps temperature telemetry might be quite useful. **On hot flying days, > 95° F, you may consider richening the "rear" carburetor's high-end needle and reduce the rpm by ~ 200 to help cool the engine.**

**Fuel – GAS** (Type of Gas and Oils Mixture Ratios)

Well filtered (~ 10 microns), 87 Octane (89 Octane is acceptable) Gasoline is recommended for all DLA Engines. Higher Octane ratings (Aviation Gas) will not improve the engine performance, and may cause the engine to perform more poorly, run slower and most often overheat. **Ethanol content of Gas in excess of 10% will void the warranty.** Select a good quality, 2-cycle oil, and mix the oil and gasoline to the following ratios:

- **Break-in and Trial Running:** 25:1 to 30:1 Gasoline:Oil
  - 30:1 is preferred
  - **Use ONLY Carbon Based, 2-cycle oil for break-in**
- **Typical Flying:** 40:1 to 50:1 Gasoline:Oil
  - 45:1 is Typical

Engine or Carburetor damage caused by fuel additives, such as nitro, alcohol, or other ingredients are not covered under the warranty. Running the improper gasoline to oil mixture ratio, running the carburetor's high-end adjustment at a too lean setting, overly-advancing the timing and engine over heating are not covered by the warranty.

A Chart of Gasoline to Oil mixture ratios is provided at the end of the manual for your convenience, on the last page of the manual.

**TANK INSTALLATION and PLUMBING:**

DLA Engines typically burn fuel at a rate, generally measured, in ounces per minute, at full throttle, as shown in the list below. The selection of the tank size is determined by several factors, such as:

- How long do you want to fly and what fuel reserve you want to maintain:
  - Ex: for a DLA 32 at 0.6 oz/min, a desired flight time of twenty (20) minutes and a 5% reserve .... A 14 to 16 oz tank would be required. ( $0.6 \times 20 \times 1.05 = 13 \text{ oz}$ )
- Fuel Consumption by engine displacement:
  - DLA 32cc                    0.20 – 0.9        oz per minute (Typ, Set up & rpm dependent)
  - DLA 58cc                    0.30 – 1.1        oz per minute (Typ, Set up & rpm dependent)
  - DLA 64cc                    0.30 – 1.4        oz per minute (Typ, Set up & rpm dependent)
  - DLA116 Twin & IL        0.42 – 2.8        oz per minute (Typ, Set up & rpm dependent)
  - DLA128cc                    0.50 – 2.8        oz per minute (estimated)

The gas or fuel tank is typically placed with the tank's center located over the aircraft's Center of Gravity (C/G) point, thus assisting in lessening the effect on the aircraft's pitch-moment as fuel is consumed from the tank. DLA engines have a "diaphragm-type" pump in the carburetor and thus the relative level of the tank's, fuel exit point to the carburetor's in-take point is not critical. However, keeping these two points at the same level can be desirable. The tank and tank "stopper" material must be compatible with gasoline. (Silicon tubing is NOT suitable for gasoline use.)

The gas line or “hose” material must be Tygon® or a similar material that is completely compatible with gasoline and the type of oil used. It is recommended that the gas line shown in the “ACCESSORIES” section of this manual be used. This gas line is available from Golden Skies R/C Aircraft, Inc. The gas or fuel lines inside diameter (ID) should be at least as big as the carburetor’s inlet nozzle diameter. The tank is shown to be semitransparent so one may see the plumbing inside the tank. The vent line is located on the outside-top of the tank and vents to the bottom of the aircraft.

The preferred fuel tank, gas line plumbing, and Fuel Point connections are shown in the following diagram. (See GS R/C Website for additional pictures) [www.goldenskiesrc.com](http://www.goldenskiesrc.com) The In-Line and 128cc QUAD dual carburetors may be supplied with gas by any of the following methods:

1. Single tank with one clunk & line and a “Tee” splitter to each carburetor, 1/8” ID line
2. Single tank with dual clunks and lines, one to each carburetor, 3/32” or 1/8” ID lines
3. Dual tanks, each with a single clunk/line to each of the two carburetors, 3/32” or 1/8” ID lines

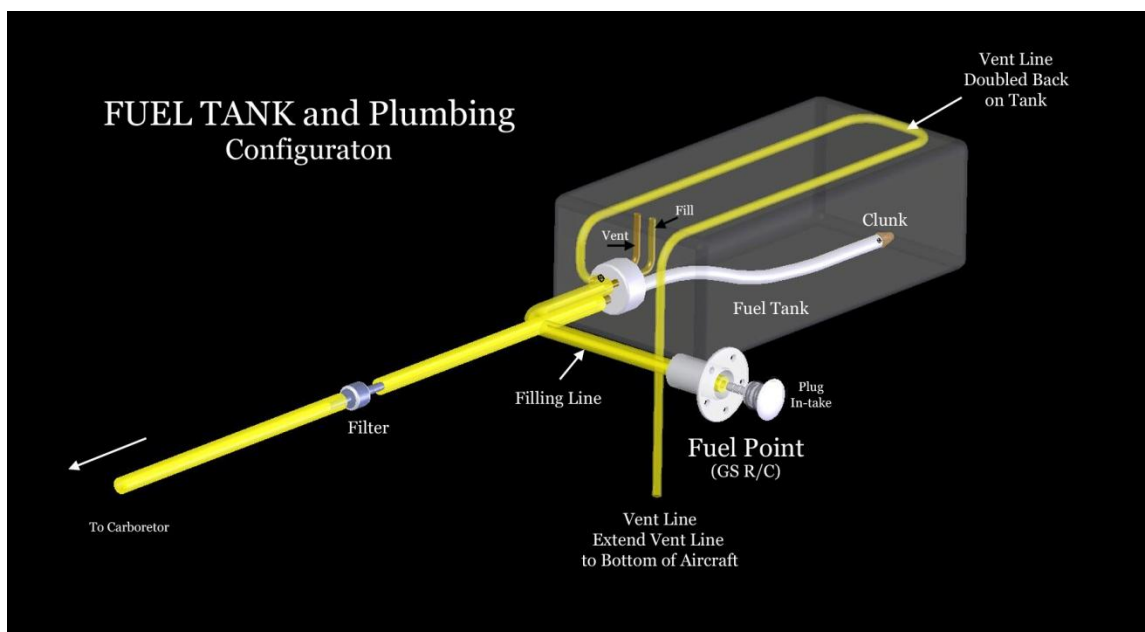

See [www.goldenskiesrc.com](http://www.goldenskiesrc.com) for other view of tank diagram

### FILTER, GAS:

It is mandatory that you filter the gasoline from the source as it is pumped into the aircraft’s fuel tank. Failure to do so can damage the carburetor and cause engine failure.

One may also place an in-line fuel filter between the aircraft’s fuel tank and the carburetor. The in-line filter must not restrict the free fuel flow from the aircraft’s fuel tank to the carburetor. An in-line filter must be periodically cleaned by back flowing clean gasoline backwards through the in-line filter. Remove the in-line filter from the carburetor supply line prior to cleaning. Never, clean

backward into the aircraft's fuel tank. Re-flush clean gas, forward through the in-line filter prior to re-installing the filter in the aircraft.

Many good filters are available commercially, consult your local hobby shop.

### FUEL POINT™

The Golden Skies R/C Aircraft, Fuel Point™ is specifically designed to make it easy to add gas to the aircraft's fuel tank. The Fuel Point™ consists for two components, 1) The barrel which mounts to the aircraft cowl or fuselage, and 2) the "Plug" that seals the gas filling line and slips into and out of the barrel. The plug is double O-ring sealed for security and has a removable flag on the surface that may be used to indicate whether the aircraft has or has not been re-fueled. The operation is to feed the Tygon® fuel line from the tank, through the barrel and attach it to the plug's barbed nipple. The plug is then inserted into the barrel for a smooth and sleek appearance on the fuselage surface. When fueling, pull the plug from the barrel, detach the fuel line from the nipple, and insert the fuel source nipple into the fuel source line. Fuel is then added to the tank, until the fuel flows out of the vent line, indicating the tank to be full. **Always "catch" the overflow as to not pollute the environment.**

### PROPELLER SELECTION:

The recommended propellers are as listed below:

DLA 32cc	18 x 8/10, 19 x 8, 20 x 8	(Diameter (in) x Pitch / Pitch range)
DLA 58cc	22 x 10, 23 x 8/10, 24 x 8	(Diameter (in) x Pitch / Pitch range)
DLA 64cc	22 x 10, 23 x 8/10, 24 x 8	(Diameter (in) x Pitch / Pitch range)
DLA 64-I2	22 x 10, 23 x 8/10, 24 x 8	(Diameter (in) x Pitch / Pitch range)
DLA 116cc	26 x 10/12, 27 x 10, 28 x 10	(Diameter (in) x Pitch / Pitch range)
DLA 116-I2	27 x 10/12, 28 x 10, 29 x 10	(Diameter (in) x Pitch / Pitch range)
DLA 128cc	27 x 10/12, 28 x 8/10, 29 x 10	(Diameter (in) x Pitch / Pitch range)
DLA 180cc	32 x 10/12/14, 33 x 10	(Diameter (in) x Pitch / Pitch range)
DLA 232cc	34 x 10, 35 x 10 / 12, 36 x 10	(Diameter (in) x Pitch / Pitch range)

Some the acceptable propeller manufacturers are:

Menz	Xoar	Vess
Mejzlik	APC	Falcon
Boala	SAIL	

Use of propeller sizes other than those specified above may either "load" or "un-load" the engine and cause damage. Un-loading the engine has the greater potential to increase the engine's rpm higher than recommended or safe for the engine. The prop type and styles may have the same "loading" and "un-loading" effect, so always check the engine's rpm with a tachometer. **ALWAYS CHECK AND RE-TIGHTEN THE PROP-BOLTS AFTER EVERY TWO OR THREE FLIGHTS.**



**DRILLING PROPELLER:**

The most reliable, consistent and safe way to drill the prop-bolts hole in the propeller is the use the GS R/C – DLA PROP HOLE DRILL GUIDE. Any other method is not recommended and can produce results that are unpredictable and potentially dangerous.

1. Place the GS R/C-DLA Prop drill guide into the propeller's center hole. Often, propellers have the center or crankshaft hole pre-drilled to ten (10) mm diameter. If the prop's center hole is not ten (10) mm, it must be drilled to 10 mm. Use only a self-centering 10 mm drill bit to produce the center hole of the proper diameter.
  - a. Drill the first prop-bolt hole using a drill press.
  - b. Use a wood back up plate under the propeller to help prevent splintering the backside of the prop-hub.
2. Place the alignment pin in the hole just drilled, passing it through the Drill-Guide and into the prop. This secures the Drill-Guide.
3. Drill remaining holes.

**DRILLING SPINNER BACK-PLATE:**

Most spinner back-plates are not specific as to the angular position of the back-plate relative to the spinner cone and thus the prop-hole locations in the back-plate are not critical. Some back-plates are solid and some have multiple holes in them for lightening. In the case of the ones with lightening holes, check to see if the existing holes will align with those required for the prop bolts. Otherwise, use either the PROP-BOLT DRILL BIT GUIDE or the engines front prop washer to mark the hole locations and drill with at least one to two (1 -2) millimeter clearance all around. When mounting the spinner, be sure the spinner back-plate holes are not in contact with the prop bolts.

**ENGINE STARTING:**

**General:**

Sometimes, when the engines have been dormant for a period of time, such as sitting in the vendor's warehouse, winter storage, etc., the carburetor gaskets can dry-out and be just a bit less flexible than when lubricated with the gas/oil mixture. In order to pump the gas/oil from the tank, a considerable amount of hand cranking may be required to draw the gas from the tank to the carburetor's nipple and then into the carb's reservoir. **Possible expediencies:**

- ✓ Remove the gas line from the carb's nipple and allow the gas to drain to end of the gas line and then re-attach to the carb's nipple.
- ✓ **Use an electric starter, rather than hand "cranking" the prop.** This creates a much greater pumping action and draws the gas to the carburetor much more quickly and save wearing out your arm. **Hand starting the engine is also not safe and is strongly NOT RECOMMEND!**
- ✓ **The above actions are particularly true and important to use when initially starting the 32cc engines.**

**Starting:**

1. Be sure the Ignition Kill Switch is in the off position, and that your ignition and receiver batteries are fully charged.
2. Add the gas:oil mixture to the fuel tank.
3. Turn on your transmitter and receiver.
4. Make sure the transmitter throttle control is in the low or idle position.
5. With the kill switch in the off position
  - a. Close the carburetor choke
  - b. Turn ignition kill switch to the on position.
  - c. Rotate the propeller (counter-clockwise, as facing the engine from the front), using an electric starter motor, until the engine starts to fire.
    - i. Stop rotating the propeller when the engine starts to fire.
    - ii. Do not rotate or "flip" the prop by hand, as that is dangerous.**
  - d. If the engine is still firing and the propeller rotating, wait for the propeller to stop.
  - e. With the propeller stopped, turn the ignition switch off and open the choke.
  - f. Turn the ignition switch back on.
  - g. Engage the electric starter and rotate the propeller until the engine starts.
  - h. Warm up the engine for twenty (20) to thirty (30) seconds before advancing the throttle.
  - i. Check to see that:
    - i. The idle is correct.
    - ii. The transitions from low to high are correct.

**ENGINE BREAK-IN:**

The engine may be broken in either on a static bench mount or on the aircraft. If using a bench mount, it is necessary to provide a soft mounting environment for the engine. A soft mount is one that significantly isolates the engine vibration from the static mount. A hard mount can stress the engine and particularly the mounting tabs. Damage often occurs in this mounting situation.

Start the engine as described above and run the engine using the break-in (Trial) gasoline to oil mixture (25:1 to 30:1). **Use only "Carbon" based 2-cycle oil and not synthetic for the break-in.** Run the engine throughout the allowable rpm range, stopping at incremental setting between: 1) idle, 2) 25%, 50%, 75%, of max-rpm and at maximum rpm, allowing the engine to run at each rpm setting for ~ 20% of the run time supported by the fuel tank capacity.

Break in the engine through approximate three to four (3 – 4) gallons of fuel.

**NORMAL FLIGHT OPERATIONS:****ENGINE MAINTENANCE:**

The engine exterior should be cleaned regularly to prevent build up of oils, gas, dirt, etc. Always store the engine with the cylinder closed to the point where the exhaust port is closed to prevent debris from getting into the engine. Also, it is good to keep the choke closed for the same reason.

Fuel tubing will deteriorate over time with symptoms of hardening, and/or discoloration. It should be checked and replaced periodically. The GOLDEN SKIES R/C AIRCRAFT, INC. gas line resists deterioration longer than typical Tygon® tubing. The fuel pick-up tube inside the gas tank will deteriorate the fastest.

Clean the carburetor screen as described in the carburetor maintenance section.

Inspect the sparkplug(s) regularly, the color and appearance is an indication of the proper gas:oil mix. Check the gap and adjust as needed.

**DIMENSIONS and PARTS DIAGRAM (Typical):**

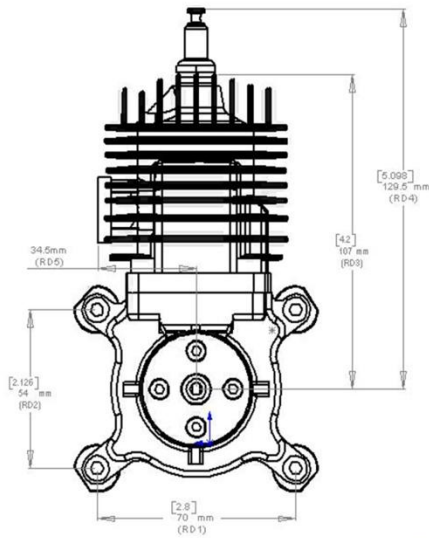
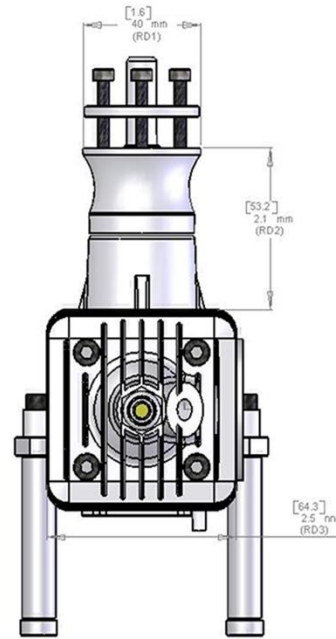
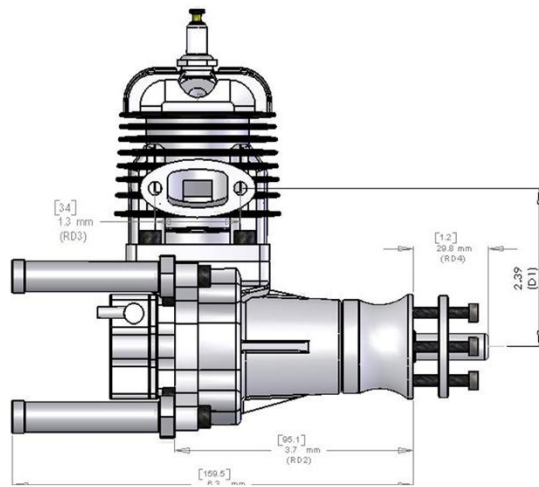

## DLA 32cc Gas Engine

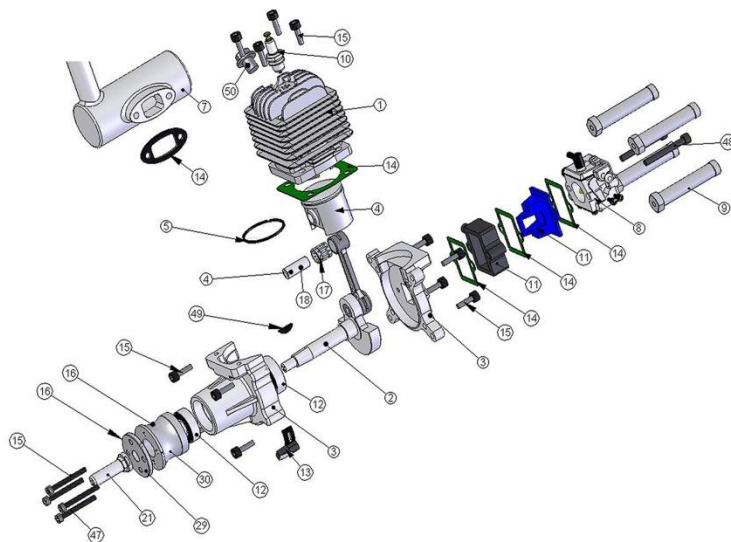



# DLA ENGINE OPERATING-INSTRUCTION MANUAL

DLA 32cc PARTS LIST - Rev: A.08.1				
FUNCTIONAL GROUPINGS	Part Numbers - Engine Components (See <a href="http://www.goldenskiesrc.com">www.goldenskiesrc.com</a> for current lists and Prices)			
	DLA 32	Dwg Key #	Part Description	STOCK
Heads	03180-01105	1	Cylinder Head, 32 / 64 / 128cc <b>STRAIGHT PLUG</b> Conf., 1-pc	IN
	03180-01127	1-S	Cylinder Head, <b>32 / 64 cc SLANTED PLUG</b> Conf., 1-pc	IN
Crankcase	03180-01107	3	Crank Case, Front & Rear, 32cc, 2- pcs	IN
	03180-01106	2	Crankshaft & Connecting Rod, 32cc, 2-pcs	IN
Cranksh	03180-01125	21	Propeller Shaft, Crankshaft Extension, 32cc, 1-pcs, per each	IN
Piston & Rings	03180-01108	4	Piston, 32 / 64 / 128cc, 1pcs, per each	IN
	03180-01109	5	Ring, Piston, Factory / Standard, 32 / 64 / 128cc, 11-pcss per each	IN
	03180-01128	24	Rings, <b>BOWMAN</b> 32, 64, 128cc, 1- pcs, per each	IN
	03180-01122	18	Wrist-Pin, Piston, Con-rod, 32 / 64 / 128cc, 1- pcs, per each	IN
	03180-01126	22	Retainers, Piston Wrist Pin, 32cc, 2- pcs, per set	IN
Ignition	03180-01110	6	Ignition Module, Capacitive Discharge., 32cc, 1-pcs, per each	IN
	03180-01114	10	Spark Plug, Iridium, (All DLA Engines), 1-pcs, per each	IN
	03180-00117	13	Sensor, Ignition, w/mounting screws, (ALL DLA Engines), 1-pcs, per each	IN
	01380-01239	35	Tachometer, (All DLA Engines), 1- pcs, per each	IN
Mufflers	03180-01111	7	Muffler, <b>Can - Std</b> , 32cc, 1-pcs, per each	IN
	01380-01106	33	Muffler, Pitts Style, DLA 32cc. 1-pcs, per each	IN
	01380-01142	39	Muffler, <b>Canister</b> , Includes: Muffler, Header, and couples, 32 & 64ccm, , <b>per set</b>	IN
Induction Stack	03180-01112	8	Carburetor, 32cc, Complete, Tillotson HU-34A, 32cc, 1- pcs, per each	IN
	03180-01115	11	Reed Valve Assembly, 4-Pedal, 32cc, 2-pcs, per set	IN
	03180-01139	32	Reed Values, Only, 4-Pedal, 32cc, 2-pcs, per set	IN
	03180-01115-I	11-I	Reed Value, Improved Version, <b>2-Pedal</b> config, 3-pcs Set. ( <b>Retrofit</b> ), <b>per set</b>	IN
	03180-01115-R		Reed Values, Only, 32cc, 2-Pedal, 2 pcs Set, ( <b>For revised engines</b> ), per set	IN
Hub & Washers	03180-01120	16	Hub, Propeller, Washer, Propeller, 32cc, 1-pcs, per each	IN
	03180-01136	29	Prop Washer, Only, 32cc, 1-pcs, per each	IN
	03180-01137	30	Prop-Hub (Only), 32cc, 1-pcs, per each	IN
Standoff	03180-01113	9	Standoffs, Engine Mounting, & Bolts, 32cc, 12-pcs, per set	IN
Bearings	03180-01116	12	Bearing Set, Front & Rear, Crankshaft (FAG), 32cc, 2-pcs, per set	IN
	03180-01116F	12F	Bearing, Front, FAG, 1- pcs, per each	IN
	03180-01116M	12M	Bearing, Main, FAG, 1-pcs, per each	IN
	03180-01121	17	Bearing Needle, Connecting-rod wrist-pin, 32 / 64cc, 12mm (IKO Bearing, Japan), 1	IN
Bolts	03180-01119	15	Bolt Set: Mounting, Complete, (all) 32cc, 18-pcs, per set	IN
	03180-01138	31	Bolts, Muffler, (All DLA Engines), 2-pcs, per set	IN
	03180-01144	48	Bolts, Carburetor, 2 ea, 5 x 0.8mm, 2-pcs	IN
	03180-01135	47	Prop Bolts, 4.0 x 0.7 - 35mm, Class 12.9, (4 ea), per set	IN
	03180-01129	15-H	Bolts, Head, 5 x .08-16mm, 32cc, 4-pcs, per set	IN
	03180-01132	15-C	Bolts, Crankcase, 5 mm, 4-pcs, per set	IN
Gaskets	03180-01118	14	Gasket Set, Complete, (Muffler, Induction Stack, Head), 32cc, 5-pcs, per set	IN
	03180-01134	41	Gasket, Muffler, 32cc Single Unit - 1 each, per each	IN
	01380-01240	36	Gasket, MUFFLER, New Style, & Bolts / Lock washers, 32cc, 5-pcs	IN
	03180-01143	40	Gasket, Muffler, Green-Paper Type, with Bolts and Lockwashers, 5-pcs, per set	IN
	03180-01130	26	Gasket, Cylinder Head, 32cc, 1-pc, per each	IN
	03180-01131	27	Gasket, Carburetor, 32cc. 1-pcs, per each	IN
	03180-01124	14-I	Gaskets, Induction Stack, 3-pcs, per set	IN
Woodruff	03180-01133	49	Key, Woodruff, 32cc, 1-pds, per each	IN
Pump Line	03180-01123	19	Fuel Line, Carb to Engine, 1-pcs, per each	IN
Filters	01380-01145	34	Air Fifter, Velocity Stack, (All DLA Engines), 1-pcs, per each	IN
	01380-01140	37	Carburetor Gasket & Diaphragm Kit (DG-11HU), for Tillotson HU-134A Carb, 32cc	NO
	01380-01141	38	Carburetor, Re-build Kit Completes (RK-31HU) for Tillotson HU-134A Carb, 32cc	NO

**PARTS LIST 58cc:** (See [www.goldenskiesrc.com](http://www.goldenskiesrc.com) for current lists and Prices)

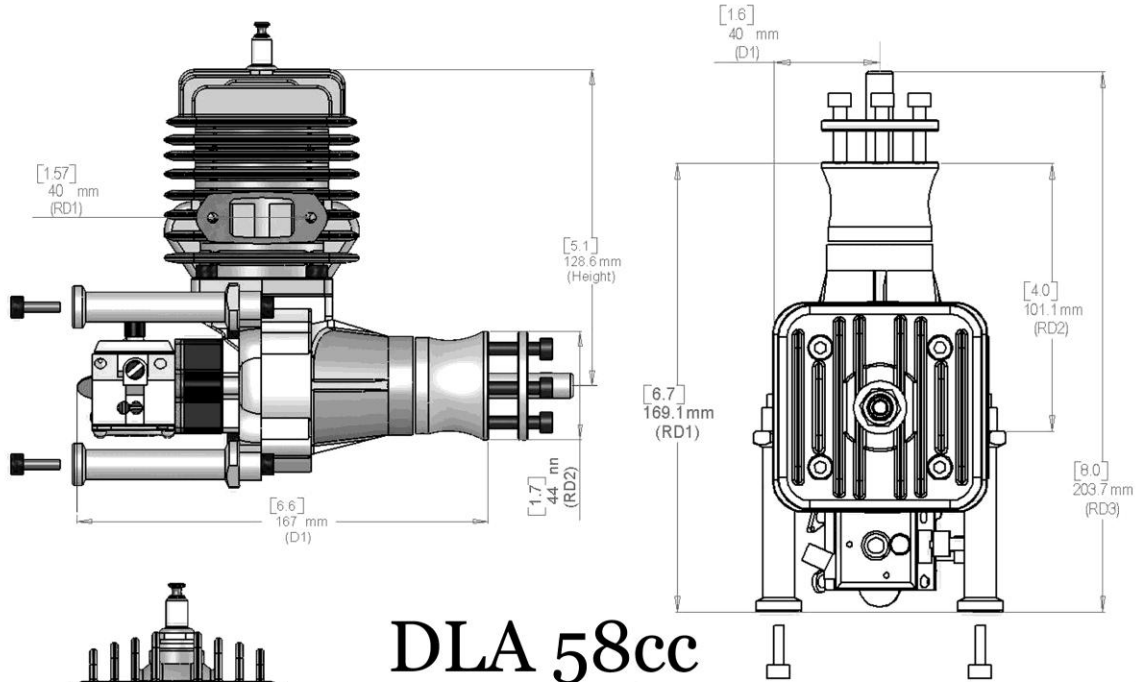

## DLA 58cc Gas Engine

See [www.goldenskiesrc.com](http://www.goldenskiesrc.com) for Parts List

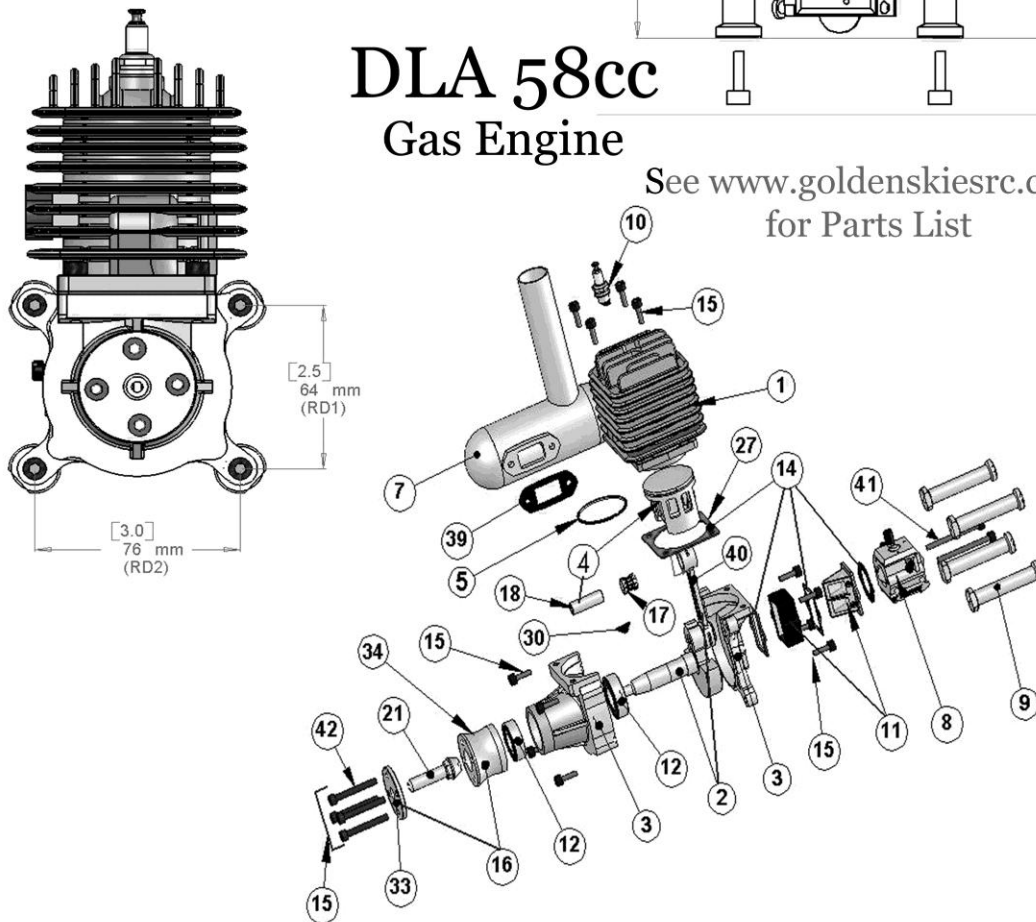

# DLA ENGINE OPERATING-INSTRUCTION MANUAL

DLA 58cc PARTS LIST - Rev: A.08			
Functional Groupings	Part Numbers - Engine Components (See <a href="http://www.goldenskiesrc.com">www.goldenskiesrc.com</a> for current lists and Prices)		
	DLA 58	Dwg Key #	Part Description
Heads	03180-01205	1	Cylinder Head, 58cc, <b>Straight Plug Config.</b> , 1-pcs, per each
	01380-01243	1S	Cylinder Head, 58cc, <b>Slanted Spark Plug</b> Config, 1-pcs, p[er each
Crankcas& Crankshaft	03180-01207	3	Crank Case, Front & Rear, 58cc
	03180-01206	2	Crankshaft & Connecting Rod, 58cc
	03180-01246	40	Con-Rod, 58cc
	03180-01225	21	Propeller Shaft, Crankshaft Extension, 58cc
	03180-01233	49	Key, Woodruff
	03180-01213	9	Standoffs, Engine Mounting, & Bolts, 58cc
Pistons & Rings	03180-01208	4	Piston & Wrist Pin w /retainers, 58cc
	03180-01209	5	Ring, Piston, 58cc
	03180-01228	5B	<b>Rings, BOWMAN</b> , 58cc / 116cc / 232cc
	03180-01222	18	Wrist-Pin, Piston, , Con-rod, 58 / 116cc
	03180-01226	22	Retainers, Piston Wrist Pin
Ignition	03180-01210	6	Ignition Module, 58cc, Capacitive Discharge.
	03180-01214	10	Spark Plug, Iridium, all engines
	03180-01217	13	Sensor, Ignition, w/mounting screws
	01380-01239	37	Tachometer
Mufflers	03180-01211	7	Muffler, <b>Std-CAN</b> , 58cc, 1-pcs, per each (Specify Left or Right)
	01380-01144	36	Muffler, <b>Pitts Style</b> , 58cc
	03180-01245	42	Muffler, <b>Canister</b> , 58cc
Induction Stack	03180-01212	8	Carburetor, 58cc, Complete, Walbro, HDA, <b>WT-247</b>
	03180-01215	11	Reed Valve Assembly, Carburetor, 58cc, 2-pcs, per set
	03180-01233	30	Reeds Only, Reed-Value, 58 / 64cc, 2-pcs, per set
	03180-01232	29	Housing, Reed-Valve (Heat Blocking), 58 / 64cc, 1-pcs, per each
Hubs	03180-01220	16	Hub, Propeller, Washer, Propeller, 58 / 64cc
	03180-01237	34	Prop-Hub ( <b>Only</b> ), 58 / 64cc
	03180-01236	33	Prop Washer, <b>Only</b> , 58cc
Bearings	03180-01216	12	Bearing Set, Front & Rear, Crankshaft, ( <b>FAG</b> ), 58cc, 2-pcs, per set
	03180-01216-F	12-F	Bearing, Front, Crankshaft, (FAG), 58cc, 1-pcs, per each
	03180-01216-M	12-M	Bearing, Main, Crankshaft, (FAG), 58cc, 1-pcs, per each
	03180-01221	17	Bearing Needle, Connecting-rod wrist-pin, 58c / 116cc / 232cc, 13mm
Bolts	03180-01219	15	Bolt Set, Complete,Mounting, Muffler, Prop Casem, 58cc, 26-Pcs, Per Set
	03180-01238	35	Bolts, Muffler, 500 x 0.8 - 16 mm, (2 ea)
	03180-01219-P	42	Bolts, Prop. 5mm, 4-pcs, Per Set
	03180-01219-H	15H	Bolts, Head, 5mm, 4-pcs, Per Set
	03180-01247	41	Bolts, Carburetor, 2-pcs, Per Set
	03180-01219-C	15-C	Bolts, Crankcase, 4-pcs, Per Set
	03180-01219--M	15-M	Bolts, Mounting, 4-pcs, Per Set
Gaskets	03180-01218	14	Gasket Set, Muffler, Carb, Head, Induction Stack, 58cc, 5-pcs, Per Set
	03180-01234	39	Gasket, Muffler, 58cc, 1-pcs, Per each
	03180-01230	27	Gasket, Cylinder Head, 58cc 1-pcs. Per Each
	03180-01231	14-H	Gasket, Carburetor, 58cc, 1-pcs, Per Each
	03180-01235	14-I	Gaskets, Induction Stack, 58cc, 3-pcs, Per Set
	03180-01223	19	Puffer - Line, Carb to Reed Valve Assembly

# DLA ENGINE OPERATING-INSTRUCTION MANUAL

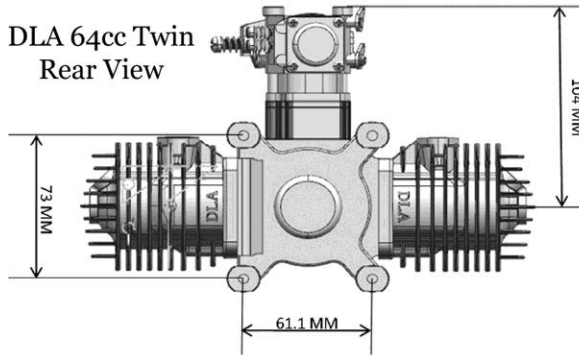
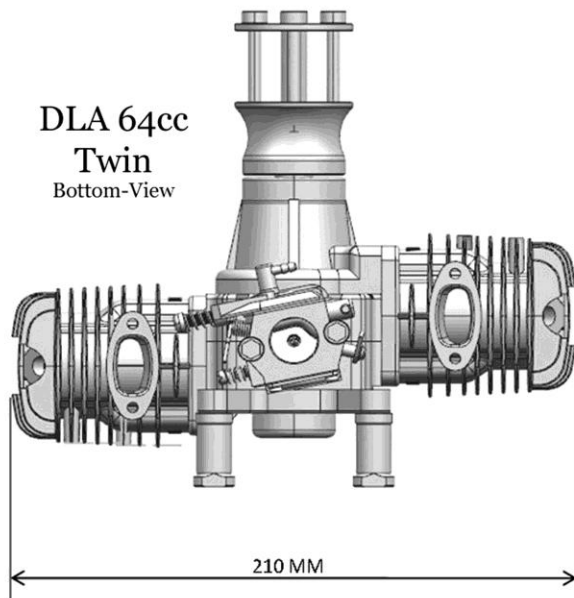
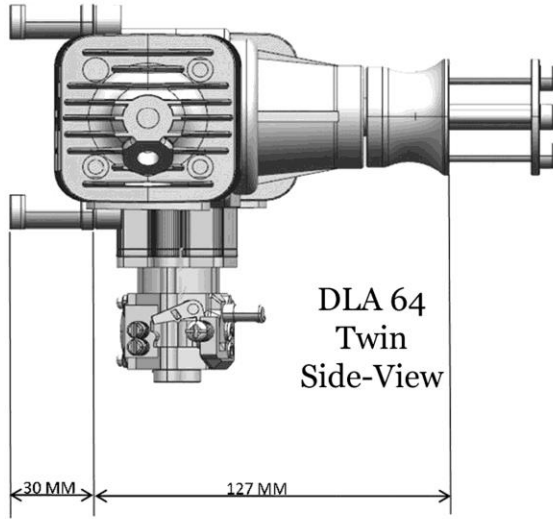

## DLA 64cc Twin Gas Engine

See [www.goldenskiesrc.com](http://www.goldenskiesrc.com)  
For Part Price List

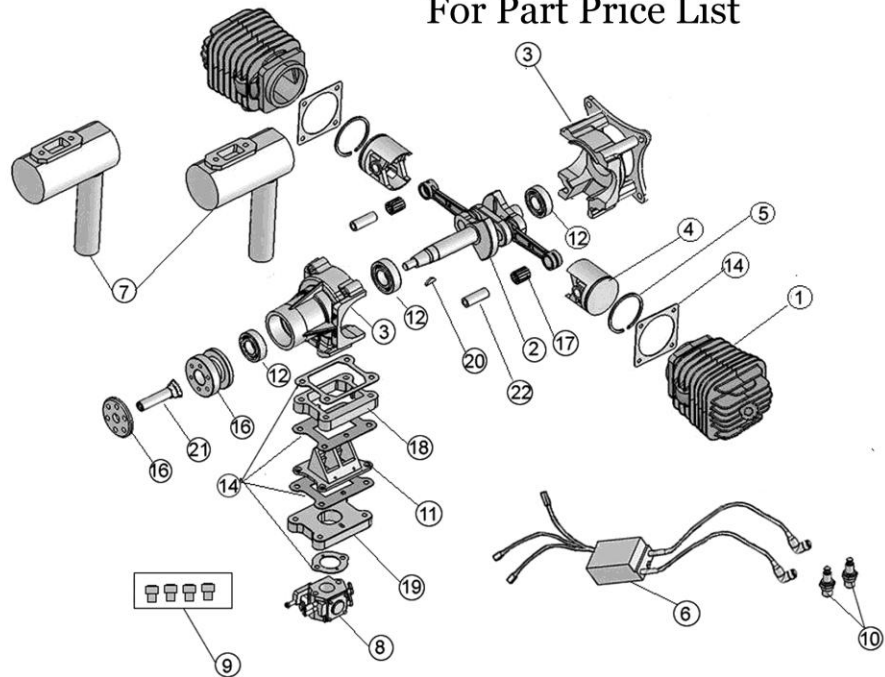



# DLA ENGINE OPERATING-INSTRUCTION MANUAL

DLA 64cc PARTS LIST - Rev: A.o8				
FUNCTIONAL GROUPINGS	Part Numbers - Engine Components			
	Prices Subject to Change without Notice on this Page			
	DLA 64	Dwg Key #	Part Description	STOCK
HEADS	03180-01105	1	Cylinder Head, 32 / 64 / 128cc, <b>Straight Sparkplug Configuration</b> , per each	IN
	103180-01105-S	1S	Cylinder Heads, 32 / 64 / 128cc, <b>Slanted Spark Plug Configuration</b> , per each	IN
CRANK SHAFT	03180-00301	2	Crankshaft & Connecting Rod, 64cc Twin Boxer, 1-pcs, per each	IN
	03180-01224	3	Propeller Shaft, Crankshaft Extension, 32 / 64 / 128cc, 1 pcs, per each	IN
	03180-00302	4	Crank Case, Front & Rear, 64cc Twin Boxer, 2 pcs, per set	IN
PISTONS	03180-01109	5	Piston & Wrist Pin & Retainers. 32 / 64 / 128cc (4 pcs). Per set	IN
	03180-01122	6	Wrist-Pin, Piston, Con-rod, 32 / 64 / 128cc, 1-pcs, per each	IN
	03180-01126	7	Retainers, Piston Wrist Pin, (All Engines), 4 pcs, per set	IN
	03180-01109	8	Ring, Piston, 32 / 64 / 128cc, 1 pcs, per each	IN
	03180-01109-B	9	<b>Rings, BOWMAN</b> 32, 64, 128cc, 1 pcs, per each	IN
IGNITION	03180-01110	10	Ignition Module, Capacitive Discharge, 64cc Twin Boxer, per each	IN
	03180-01114	11	Spark Plug All Engines, 1 pcs, per each	IN
	03180-01115	12	Plug & Copper Gasket, Sparkplug Hole, All Engines. 2-pcs, per set	IN
	03180-00117	13	Sensor, Ignition, w/mounting screws, All Engines, 1-pcs, per each	IN
Mufflers	03180-00303	14	Muffler, 64cc Twin Boxer, 1-pcs, per each	IN
	01380-01142	15	Muffler, <b>Canister</b> , Includes: Muffler, Header, and coupler/clamps (1 each), 32 & 64cc	IN
INDUCTION STACK	03180-01212	16	Carburetor, 64cc, Complete, 58 / 64cc Walbro HAD, 1-pcs, per each	IN
	03180-01215	17	Reed Valve Assembly, Carburetor, 64cc Twin Boxer, 2-pcs, per set	IN
	01380-00304	18	Base / Mount, Carburetor, 64cc, 1-pcs, per each	IN
	03180-01232	19	Housing, Reed-Valve (Heat Blocking), 58 / 64cc, 1-pcs, per each	IN
	03180-01233	20	Reeds Only, Reed-Value, 58 / 64cc, 2-pcs, per set	IN
PROP HUBS	03180-01220	21	Hub, Propeller, Washer, Propeller, 58 / 64cc, 2-pcs, per set	IN
	03180-01237	22	Prop-Hub Only, 58 / 64cc, 1-pcs, per each	IN
	03180-01236	23	Prop Wash, 64cc, Only, 1-pcs, per each	IN
	03180-01318	24	Standoffs, Engine Mounting, 64cc, 4-pcs, per set	IN
BEARINGS	03180-00305	25	Bearing Set, Front, Middle & Rear, Crankshaft ( <b>FAG</b> ), 64cc Twin Boxer, 3-pcs, per set	IN
	03180-00305-F	26	Bearing, Front, 1-pcs, per each	IN
	03180-00305-M	27	Bearing, Main, 1-pcs, per each	IN
	03180-00305-E	28	Bearing, End, 1-pcs, per each	IN
	03180-01121	29	Bearing Needle, Connecting-rod wrist-pin, 32 / 64cc, 12mm, 1-pcs, per each	IN
BOLTS	03180-00306	30	Bolt-Set, 24-pcs, per set	IN
	03180-00307	31	Bolts, Muffler, All Engines, 2-pcs, per set of 2	IN
	03180-00308	32	Bolts, Head / Cylinder, 4-pcs, per set of 4	IN
	03180-00310	34	Bolts, Crankcase, 4-pcs, per set of four.	IN
	03180-00311	35	Bolts, Stand-offs, 8-pcs, per set of 8	IN
	03180-00312	36	Bolts, Carburetor, 2-pcs, per set of 2	IN
	03180-00313	37	Bolts, Carburetor - Mounting Plate, 2-pcs, per set of 2	IN
	03180-00314	38	Bolts, Propeller, 4-pcs, per set of 4	IN
GASKETS	03180-00315	39	Gasket Set, 64cc, 8-pcs, per set of 8	IN
	03180-00316	40	Gasket, Muffler, 32 / 64 / 128cc, 2-pcs, per set of 2	IN
	03180-00317	41	Gasket, Cylinder Head, 32 / 64 / 128cc, 2-pcs, per set of 2	IN
	03180-00318	42	Gaskets - Induction Stack, 64cc, 4-pcs, per set of 4	IN
	03180-00319	43	Gasket Carburetor, 1-pcs, per each	IN
	03180-00320	44	Key, Woodruff, 64c, 1-pcs, per each	IN
	01380-01239	45	Tachometer, (All DLA Engines), 1-pcs, per each	IN
	03180-00321	-	Header, Canister, 64cc, 1-pcs, per each	IN



# DLA ENGINE OPERATING-INSTRUCTION MANUAL

## DLA 64-I2

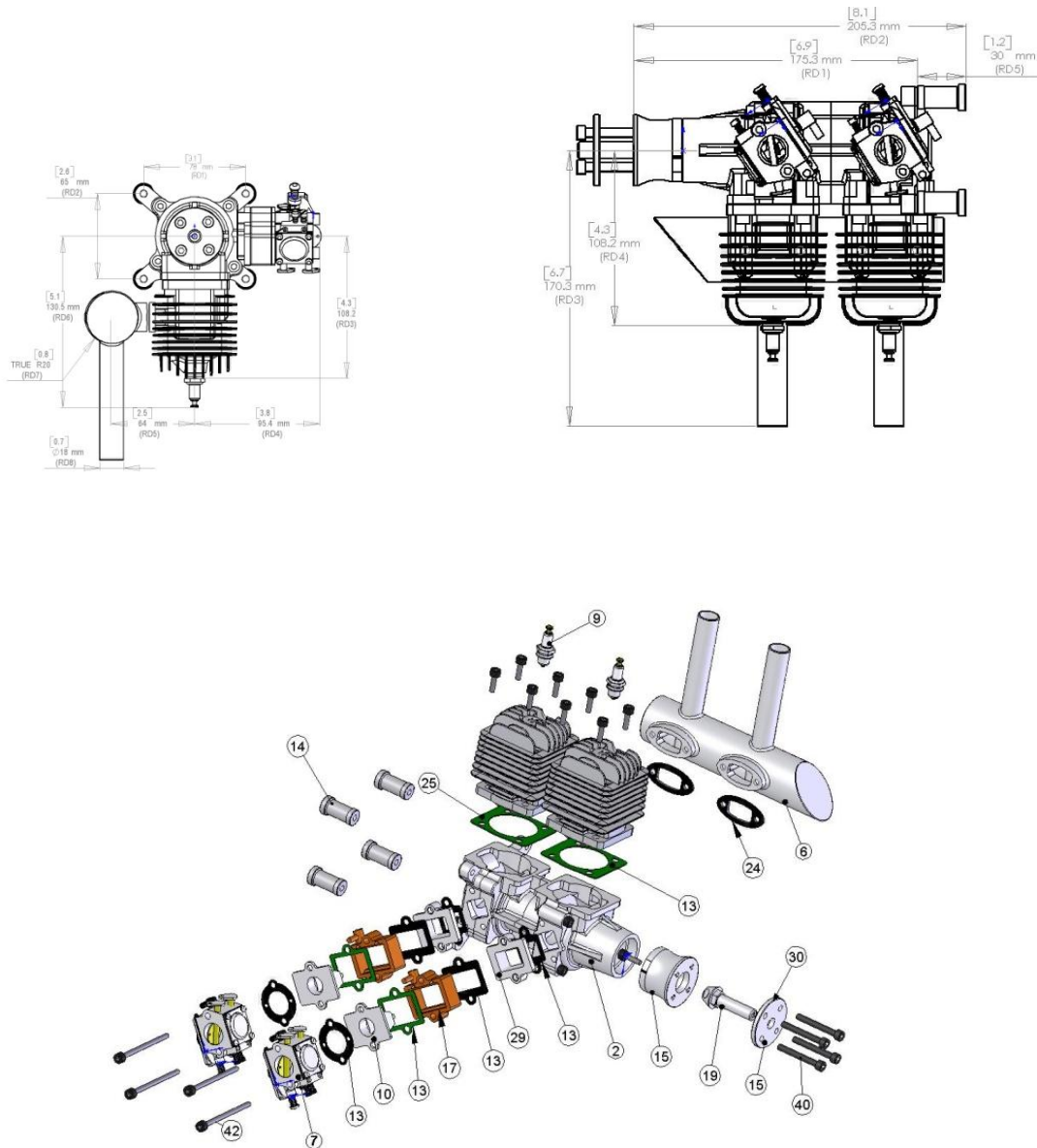

# DLA ENGINE OPERATING-INSTRUCTION MANUAL

FUNCTIONAL GROUPINGS	DLA 64CC-I2 Parts List Rev: A 8.00	
	Part Numbers - Engine Components (See <a href="http://www.goldenskiesrc.com">www.goldenskiesrc.com</a> for current lists and Prices)	
DLA 64-I2	Dwg Key #	Part Description
03180-01105	1	Cylinder Head, 32 / 64 / 128cc <b>STRAIGHT PLUG</b> Conf., per each
03180-01127	1-S	Cylinder Head, <b>32 / 64 cc SLANTED PLUG</b> Conf., 1-pc, per each
03180-00702	2	<b>Short-Block 64-I2 - Assembled</b> , , Incls: Crankcase, Crankshaft, Con-rods,
03180-00709	14	Standoffs, Engine Mounting, <b>64-I2</b> cc. per set of 4
03180-01324	19	Propeller Shaft, Crankshaft Extension, 58 / 64 / <b>64-I2</b> , per each
03180-01319	15	Hub & Washer, Propeller, 64, 58, <b>64-I2. 2-pcs</b>
03180-01335	28	Prop-Hub (Only), 58 / 64 / <b>64-I2</b> cc, per ach
03180-01133	18	Key, Woodruff, All New Engines, 13.7 x 4.33 x 3 mm, per each
03180-01337	30	Prop Wash, Only. 58 / 64 / <b>64-I2</b> , per each
03180-01108	3	Piston, 32 / 64 / 128cc (Incls: Wrist-pin & 2 ea retainer clips), per each
03180-01109	4	Ring, Piston, 32, 64, 128cc, per each
03180-01128	22	<b>Rings, BOWMAN</b> 32, 64, <b>64-I2</b> , 128cc, per each
03180-01126	38	Retainers, Piston Wrist-Pin, 32 / 64 / <b>64-I2</b> / 128cc, set of 4 pcs
03180-01122	21	Wrist-Pin, Piston, , Con-rod, 32 / 64 / <b>64-I2</b> / 128 cc, per each
03180-01110	5	Ignition Module, Capacitive Discharge., 32cc / 58cc / 64-I2 / 116-I2 (ea)
03180-00117	26	Sensor, Ignition, All Engines, w/mounting screws, per each
03180-01114	9	Spark Plug, Iridium, Universal, per each
03180-01115	12	Plug & Copper Gasket, Sparkplug Hole, All Engines. 2-pcs, per set
01380-01239	37	Tachometer, (All DLA Engines)
03180-00703	6	Muffler, <b>64-I2</b> cc In-line, per each
01380-01143	35	Muffler, <b>Canister</b> , Includes: Muffler, Header, and coupler/clamps (1 each), 32 & 64cc (2 required for 64cc)
03180-01112	7	Carburetor, 32 / 64-I2cc, Complete, Tillotson HU-134A, 32cc, per each
03180-00705	10	Reed Valve Assembly - Induction Stack, <b>64-I2</b> , Carburetor, per each
03180-00712	27	Reed Valve, <b>64-I2</b> , Only, per each
03180-00710	17	Heat Block, Reed Valve Housing, <b>64-I2</b> , per each
03180-00713	10	Adapter-Base, Reed-Valve, Carburetor, <b>64-I2</b> , per each
03180-00714	40	Choke & Throttle Connecting Linkage and Ball-end Connectors, 64-I2 (ea)
03180-00706	11	Bearing Set, Front, Rear, <b>64-I2</b> Crankshaft ( <b>FAG</b> )
03180-01121	16	Bearing Needle, Connecting-rod wrist-pin, 32 / 64 / 128cc, <b>12 mm</b> , ea
03180-00715	41	Bolt Set Complete, 28-pcs, Per Set
03180-00704	8	Bolt-Set, Mount, 4-pc, Per Set
03180-00707	12	Bolts, Muffler or Head, 1-pcs, per each
03180-00716	42	Bolts, Carburetor, 64-I2, 1-pcs, per each (2-required)
03180-01341	40	Bolts, Propeller, 4-pcs, Per Set
03180-00708	13	Gasket Set, <b>64-I2</b> , Muffler, Carburetor / Induction Stack, Cylinder Head, 12 pcs
03180-00711	13-C	Gasket, Carburetor, <b>64-I2</b> cc, 1 pc, per each
03180-01331	24	Gasket, Muffler. 32 / 64 / <b>64-I2</b> / 128 cc, 1-pcs,per each
03180-01130	13-H	Gasket, Cylinder Head, 32 / 64 / 128cc, 1-pcs, per each
03180-01340	13-I	Gaskets, Induction Stack, 32 / 64 / <b>64-I2</b> cc, 4-pcs, Per Set

# DLA ENGINE OPERATING-INSTRUCTION MANUAL

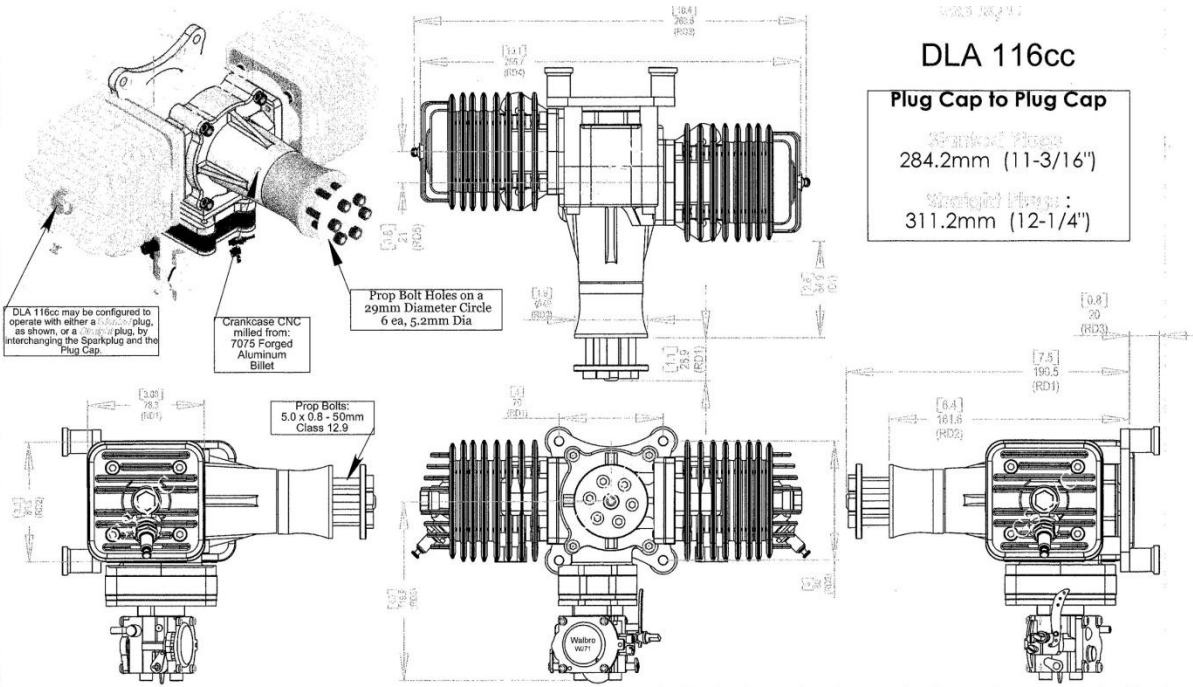

**DLA 116cc**  
**Plug Cap to Plug Cap**  
 Spark Plug: 284.2mm (11-3/16")  
 Glow Plug: 311.2mm (12-1/4")

SCALE 1 : 3

PROHIBITION AND RESTRICTIONS  
 THE INFORMATION CONTAINED IN THIS DRAWING IS THE SOLE PROPERTY OF SCHAINTZ R/C. ANY REPRODUCTION IN PART OR AS A WHOLE WITHOUT THE WRITTEN PERMISSION OF SCHAINTZ R/C AIRCRAFT, LLC IS PROHIBITED.

APPLICATION  
 NEXT ASSY USED ON  
 R/C Model Aircraft

UNLESS OTHERWISE SPECIFIED:  
 DIMENSIONS ARE IN: [inches]  
 MATERIAL: 7075 Aluminum  
 FINISH

DRAWN  
 CHECKED  
 COMMENTS:  
 1. Timing Sensor not shown.

NAME DATE  
 Schantz 8-27-18

TITLE:  
**DLA 116cc**  
**Twin Boxer**

SIZE DWG. NO. REV  
**A** 03180-00440 **B**

SCALE: 1:3 WEIGHT: 104.8 oz SHEET 1 OF 1

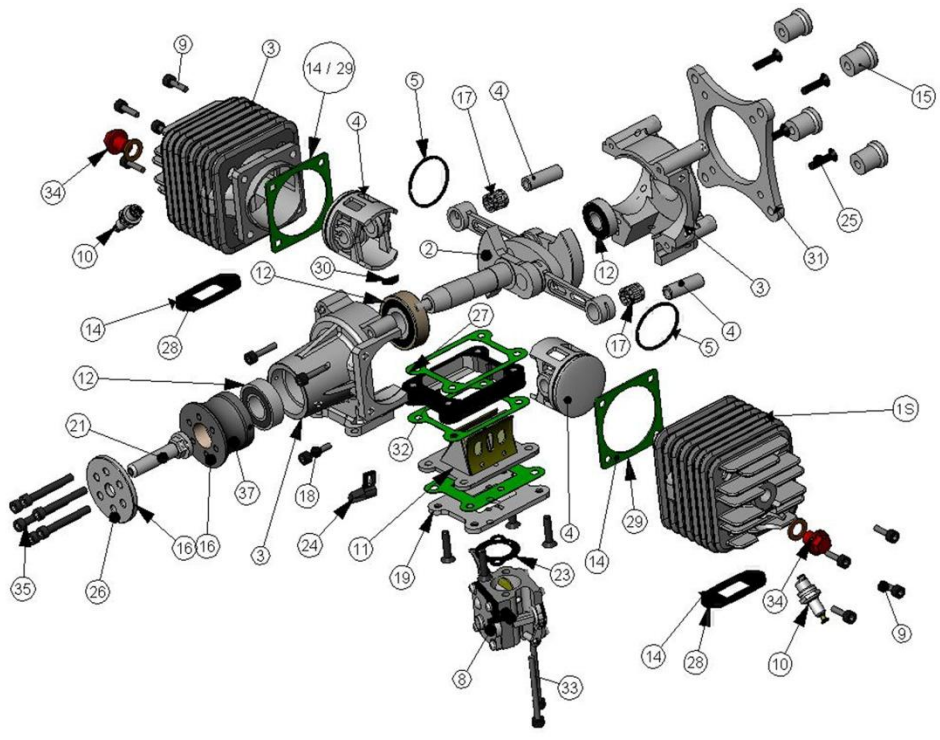

# DLA ENGINE OPERATING-INSTRUCTION MANUAL

DLA 116cc PARTS LIST - Rev: A.o8				
Functional Groupings	Part Numbers - Engine Components			STOCK
	Prices Subject to Change without Notice on this Page			
	DLA 116	Dwg Key #	Part Description	
Heads	03180-01404	1	Cylinder Head, 58cc / 116 / 232cc, <b>Straight Plug Configuration</b>	IN
	01380-01243	1S	Cylinder Head, 58 / 116 / 232cc, <b>Slanted Spark Plug Configuration</b>	IN
Crankcase Crankshaft	03180-01406	3	Crank Case, Front & Rear, 116cc	IN
	03180-00405	2	Crankshaft & Connecting Rod, 116cc	IN
	03180-01433	30	Key, Woodruff, 116cc	IN
	03180-01424	21	Propeller Shaft, Crankshaft Extension	IN
	03180-01434	31	Mount Base, Ring, Engine	IN
	03180-01418	15	Standoffs, Engine Mounting, 116cc (4 ea)	IN
Pistons & Rings	03180-01407	4	Piston, Wrist Pin & Retainers, 58 / 116cc (Piston Dia: 45.8 mm)	IN
	03180-01408	5	Ring, Piston ( <b>DLA Factory</b> ), 58cc / 116 / 232cc	IN
	03180-01228	5B	<b>Rings, BOWMAN</b> , 58 / 116cc	IN
	03180-01222	4	Wrist-Pin, Piston, , Con-rod, 58 / 116cc	IN
	03180-01425	22	Retainers, Piston Pin	IN
IGNITION	03180-01409	6	Ignition Module, Capacitive Discharge., 64 / 116 / 232cc	IN
	03180-01413	10	Spark Plug, (All DLA Engines)	IN
	03180-01338	34	<b>Plug Cap &amp; Washer (1 ea)</b>	IN
	03180-01427	24	Sensor, Ignition, w/mounting screws	IN
	01380-01239	41	Tachometer, (All DLA Engines)	IN
Mufflers	03180-01410	7	Muffler, <b>Std CAN, Left or Right</b> , each, 116cc	IN
	03180-01406	40	Muffler, <b>Cannister</b> , 58 / 116cc, 1-pc, Per Each	IN
Induction Stack	03180-01411	8	Carburetor, <b>116cc</b> , Complete, Walbro WJ71 - 311	IN
	03180-01414	11	Reed Valve Assembly, Carburetor, 116cc	IN
	03180-01435	32	Heat Block / Reed-Valve Housing, 116cc	IN
	03180-01422	19	Mounting Base, & 4 ea Flat Head Bolts, Carburetor	IN
	03180-01439	36	Reed Valve, Only, 116cc	Call
Hubs	03180-01419	16	Hub, Propeller, Washer, Propeller, 116 / 116-I2cc	IN
	03180-01429	26	Prop Wash, Only, 116cc	IN
	03180-01440	37	Prop-Hub, Only, 116cc	IN
Bearings	03180-01415	12	Bearing, Crakshaft Set, Front, Middle & Rear, 116cc	IN
	03180-01420	17	Bearing Needle, Connecting-rod wrist-pin, 58 / 116 / 232cc, 13mm	IN
Bolts	03180-01412	all	Bolt- <b>Set</b> , Complete, 116cc 30-pcs, Per Set	IN
	03180-01428	25	<i>Bolts, (Mounting Plat to Crankcase), Flat Head. (4 ea)</i>	IN
	03180-01436	33	<i>Bolts, Carburetor, (2 ea), Per set of 2</i>	IN
	03180-01416	9	Bolts, Muffler or Head, (All DLA Engines), 1-pcs , per each	IN
	03180-01438	35	Bolt-Set, Prop., 116cc, 4 ea, Per set of 4	IN
	03180-01423		<i>Bolt Set, Carb Mount Plate, Flat Head, 4-pcs, Per Set of 4</i>	IN
Gaskets	03180-01421	18	<i>Bolt Set, Crankcase, 4-pcs, Per Set of 4</i>	IN
	03180-01417	all	Gasket <b>Set</b> , All, 116cc, 8pcs, Per Ser of 8	IN
	03180-01430	23/27/32	Gasket, Induction Stack, 116cc. (4 pcs), per set	IN
	03180-01426	23	Gasket, Carburetor, 116cc	IN
	03180-01432	29	Gasket, Cylinder Head, 58 / 116 / 232cc, 2-pcs, Per set of 2	IN
	03180-01431	28	Gasket, Muffler, 58 / 116cc, 1-pcs, per each	IN
	03180-01443	44	Heat Shield Material, 50 sq-in	IN
	03180-01405	39	Air Filter, 90 deg, (All DLA Engines)	IN



# DLA ENGINE OPERATING-INSTRUCTION MANUAL

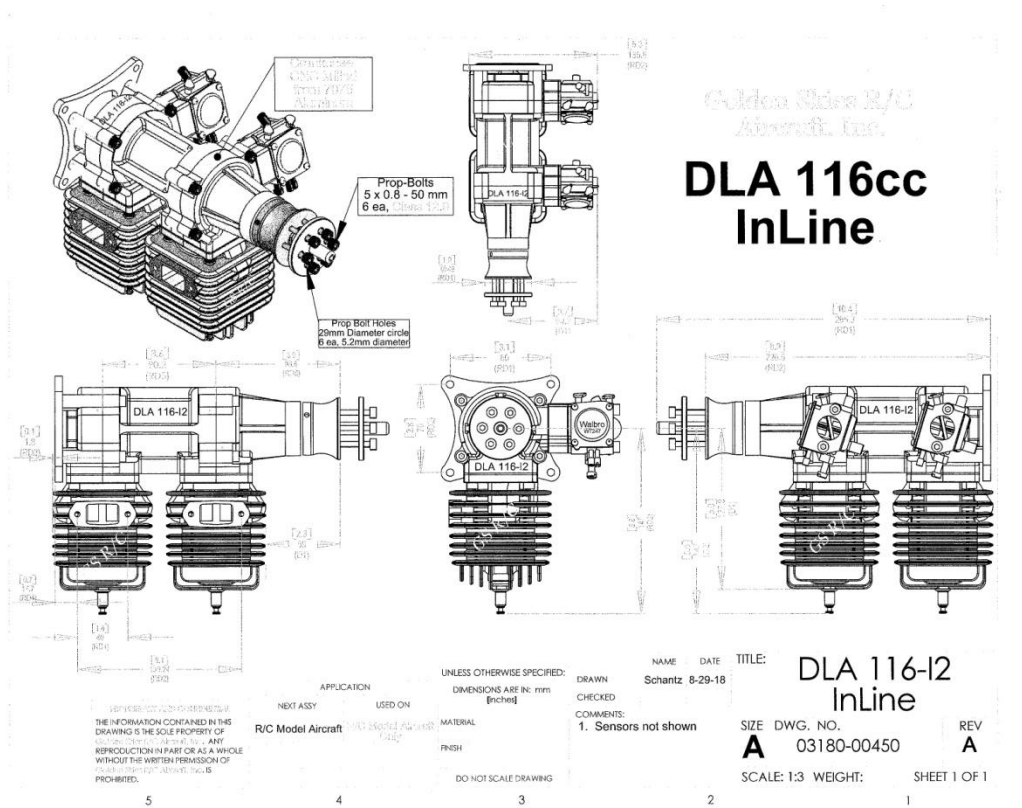

DLA 116-I2

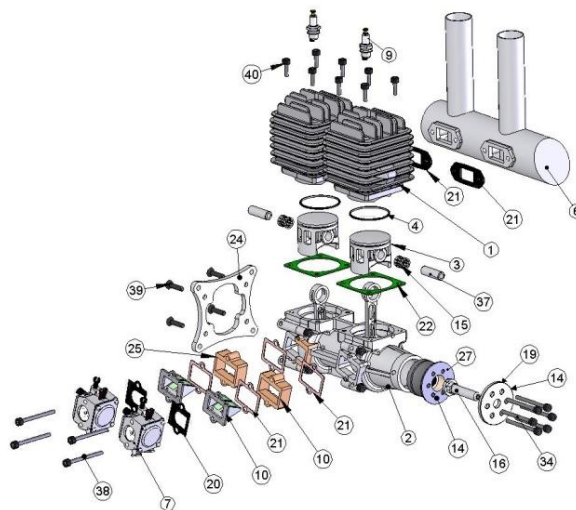



# DLA ENGINE OPERATING-INSTRUCTION MANUAL

## DLA 116cc-I2 PARTS LIST - Rev: A.o8

Part Numbers - Engine Components  
(See [www.goldenskiesrc.com](http://www.goldenskiesrc.com) for current lists and Prices)

DLA 116-I2	Dwg Key #	Part Description
03180-01205	1	Cylinder Head, 58, 116, 232 cc, <b>Straight Plug Config.</b> , Per each
01380-01243	1-S	Cylinder Head, 58cc, <b>Slanted Spark Plug Configuration</b> , per each
03180-02405	2	<b>SHORT BLOCK:</b> Crankshaft & Connecting Rod, Crankcase (F/M/R), Bearings (7) , <b>116-I2 cc</b> , In-Line
03180-02434	24	Mount Base, Ring, 1-pcs, per each
03180-02418	-	Standoffs, Engine Mounting, <b>116-I2cc</b> , 4-pcs, per set
03180-01424	16	Propeller Shaft, Crankshaft Extension. 116 / <b>116-I2</b> , 1-pcs, per each
03180-01133	-	Key, Woodruff, All New Engines, 1-pcs, per each
03180-01419	14	Hub, & Washer, Propeller, 116cc, 116cc-I2, 128cc, 2-pcs, per set
03180-01440	27	Prop-Hub, Only, <b>116 / 116-I2cc</b> , 1-pcs, per each
03180-01429	19	Prop Wash, Only, 116cc, 116-I2, 128cc, 1-pcs, per each
03180-01208	3	Piston & Wrist Pin w /retainers, 58, 116, 232cc, 4-pcs, per set
03180-01209	4	Ring, Piston, 58, 116, 116-I2, 232 cc, 1-pcs, per each
03180-01228	4-B	<b>Rings, BOWMAN</b> , 58 / 116 / 232 cc, 1-pcs, per each
03180-01222	37	Wrist-Pin, Piston, , Con-rod, 58 / 116cc, 1-pcs, per each
03180-01425	-	Retainers, Piston Wrist-Pin, 4- pcs, per set
03180-01115	-	Plug & Copper Gasket, Sparkplug Hole, All Engines. 2-pcs, per set
03180-01110	-	Ignition Module, Capacitive Discharge., <small>32cc / 58cc / 64-I2 / 116-I2</small> , 1-pcs, per each
03180-01114	9	Spark Plug, (All DLA Engines), 1-pcs, per each
03180-00117	-	Sensor, Ignition, w/mounting screws, 3-pcs, per set
01380-01239	-	Tachometer, (All DLA Engines), 1-pcs, per each
03180-02410	6	Muffler, CAN, each, <b>116-I2cc</b> , 1-pcs, per each
03180-02406	-	Muffler, <b>Cannister</b> , 58 / 116cc, 1-pcs, per each
03180-01212	7	Carburetor, 58cc, 116-I2, Complete, Walbro HDA, 9cs, per each
03180-02414	10	Reed Valve / Induction Stack, <b>116-I2</b> , Assembly, 2-pcs, per set
03180-01435	10-B	Heat Block / Reed Value Housing, <b>116-I2 cc</b> , 1-pcs, per each
03180-00452	-	Choke or Throttle Connecting Linkage and Ball-end, per each link set
03180-01405	-	Air Filter, (All DLA Engines, 1-pcs, per each
	-	Bearing Set, Front, Rear, <b>116-I2 Crankshaft (FAG)</b> , 2-pcs, per set
03180-01221	15	Bearing Needle, Con-rod wrist-pin, 58 / 116cc, <b>1-pcs, per each</b>
03180-01438	26	Bolt-Set, All, 116-I2cc, 34-pcs, per set
03180-01416	-	Bolts, Muffler, (All DLA Engines), 4-pcs, per set of 4
03180-01412	34	Bolt-Set, Prop., <b>16-I2cc</b> , 6-pcs, Per set
03180-02436	40	Bolts, Cylinder Head, 1-pcs, per each
03180-02405	38	Bolts, Carburetor, 5 x 0.8 mm, 1-pcs, per each
03180-02435	39	Bolts, Mounting Ring, 5 x 0.8 Flat Heat, 3mm Hex Dr, 4-pcs, per each
03180-02417	-	Bolts, Crankcase, 1-pcs, per each
03180-01432	22	Gasket, Cylinder Head, 58 / 116 / 232 cc, 1-pcs, per each
03180-02430	20	Gasket, Carburetor, <b>116-I2 cc</b> , 1-pcs, per each
03180-01431	21	Gasket, Muffler, 58 / 116 / 232cc, 1-pcs, per each
03180-00451	20 / 21	Gaskets, Induction Stack, 3-pcs, Per Set
03180-02442	-	Gaskets (2), Muffler, Bolts & Lockwashers, 116cc, 10-pcs, per set

# DLA ENGINE OPERATING-INSTRUCTION MANUAL

## DLA 180cc Twin Boxer

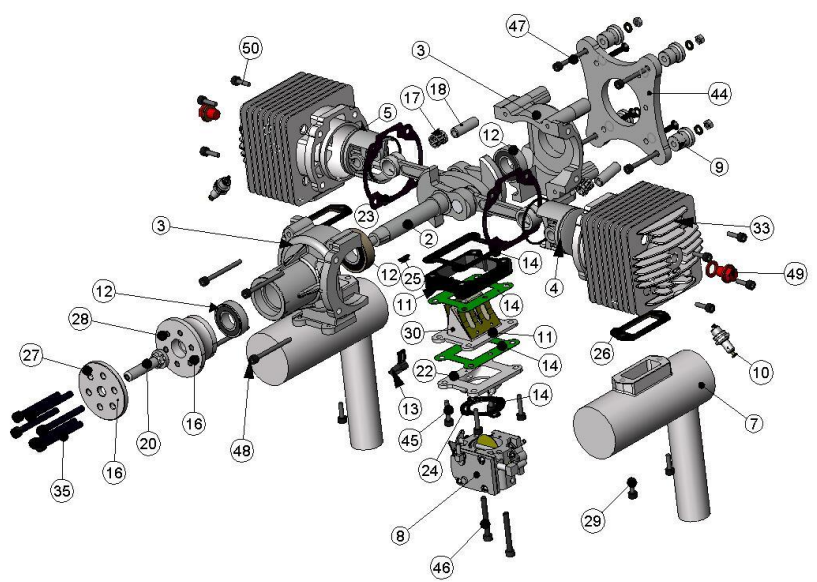
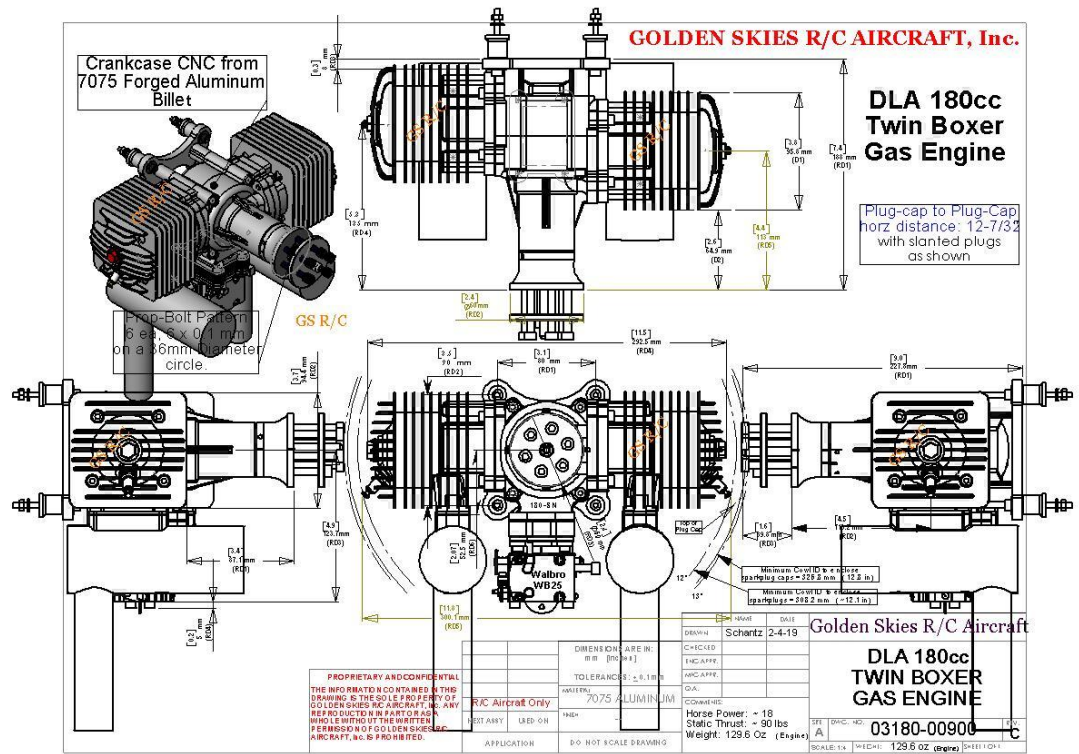

# DLA ENGINE OPERATING-INSTRUCTION MANUAL

DLA 180 PARTS LIST - Rev: A.08.01				
Functional Groupings	Part Numbers - Engine Components <span style="color: red; font-size: small;">Prices Subject to Change without Notice on this Page</span>			
	DLA 180 Part Numbers	Dwg Key #	Part Description	STOCK
HEADS	03180-00907	1	Cylinder Head, Straight Plug Configuration, 180cc, 1-pcs, (per each)	IN
	03180-00938	1-S	Cylinder Head, 180cc, <span style="color: red;">SLANTED PLUG Configuration, 1-pcs, per each</span>	IN
CRANKCASE CRANKSHAFT & HUBS	03180-00909	3	Crank Case, Front & Rear, 180cc, 2-pcs, per set	IN
	03180-00908	2	Crankshaft & Connecting Rod, 180cc, 1-pvs, per each	IN
	03180-00926	20	Propeller Shaft, Crankshaft Extension, 116 / 180cc, per each	IN
	03180-00922	28	Hub & Washer, Propeller, 180cc, per ser of 2-pcs, 1-pcs, per set	IN
	03180-00935	16	Prop-Hub (Only), 180cc, 1-pcs, per each	IN
	03180-00934	27	Prop Washer, Only, 180cc, 1-pcs, per each	IN
	03180-00932	25	Key, Woodruff, 180cc, 1-pcs, per each	IN
	03180-00931	44	Mount, Plate, 180cc, 1-pcs, per each	IN
Pistons & Rings	03180-00915	9	Standoffs, Engine Mounting, & Bolts, 180, 4-pcs, per set	IN
	03180-00910	4	Piston, 180cc, Wrist pin, Retainer Clips, 4-pcs, per set	IN
	03180-00911	5	Ring, Piston, 180cc, 1-pcs, per each	IN
	03180-00925	5-B	<span style="color: blue;">Rings, BOWMAN</span> 180cc, 1-pcs, per set	Call
	03180-00924	18	Wrist-Pin, Piston, Con-rod, 180cc, 1-pcs, per each	IN
IGNITION	03180-00927	-	Retainers, Piston Pin, 180cc, 4-pcs, set	IN
	03180-01310	-	Ignition Module, Capacitive Discharge., 64/112/116/128/180cc, 1-pcs, per each	IN
	03180-01114	10	Spark Plug, Iridium (All DLA Engines), 1-pcs, per each	IN
	03180-00117	13	Sensor, Ignition, w/mounting screws ( <span style="color: red;">All DLA Engines</span> ), 3-pcs, per set	IN
	03180-00950	49	Plug & Gasket, Sparkplug Cap, 2-pcs, per set	IN
MUFFLE RS	01380-01239	-	Tachometer, (All DLA Engines), 1-pcs, per each	IN
	03180-00913	7	<span style="color: red;">Muffler, CAN</span> , 180cc, 2-pcs, per pair	IN
	03180-00946	-	<span style="color: red;">Muffler, Canister and Header</span> Set, per set	IN
INDUCTION STACK	03180-00947	-	Header, Cannister - 180cc, per each	IN
	03180-00914	8	Carburetor, 180cc, Complete, <span style="color: red;">Walbro WB 25-429</span> , 1-pcs, per each	IN
	03180-01414	11 & 30	Reed Valve Assembly, Carburetor, 180cc 2-pcs. per set	IN
	03180-00928	22	<span style="color: red;">Base</span> , Carburetor, 1-pcs, per each	IN
	03180-00939	11	Housing, Reed-Valve Heat Blocker, 180cc, 1-pcs, per each	IN
	03180-00937	-	Reed Values, Only, 180cc, 2-pcs, per set	IN
BEARINGS	03180-00938	-	Velocity Stack, Air Filtter, 90 deg, 180cc, 1-pcs, per each	IN
	03180-00918	12	Bearing Set, Front, Middle & Rear, Crankshaft (FAG), 180cc, 3-pcss, per set	IN
BOLTS	03180-00923	17	Bearing Needle, Connecting-rod wrist-pin (IKO Bearing, Japan), 180cc, per each	IN
	03180-00948	35-47-49-23-48-49-50	Bolt Set, Complete, 32-pcs, per set	IN
	03180-02033	35	Bolt, Prop 6 x 1.0 - 60 mm, 1-pcs, per each	IN
	03180-00936	29	Bolt Set, Muffler, (all DLA Engines, 2-pcs, per set	IN
	03180-00921	47	Bolt, Mounting, 180 / 232cc, <span style="color: red;">6.0 x 1.0 - 55</span> mm, 1-pcs, per each	IN
	03180-00942	47S	Bolt Set, Engine Mounting, w/washers & Nuts, Per Set of 16 pcs, per set	IN
	03180-00941	45	Bolt, Carburetor Plate, 1-pcs, per each	IN
	03180-00951	50	Bolt Set, Cylinder - Head, 4-pcs, per set	IN
GASKETS	03180-00949	48	Bolt Set, Crankcase, 4-pcs. set of 4 pcs	IN
	03180-00920	14-26-23	Gasket Set, ALL, 180cc, 8-pcs, per set	IN
	03180-00933	26	Gasket, Muffler, 180cc, 1-pcs, per each	IN
	03180-00930	24	Gasket, Carburetor, 180cc, 1-pcs, per each	IN
	03180-00940	14	Gasket Set, Induction Stock, 4-pcs, per set	IN
	03180-00929	23	Gasket, Cylinder Head, 180cc, 1-pcs, per each	IN
MISC	03180-00939	26S	Gasket Set, Muffler, & Bolts / Lock washers, 180cc, 5-pcs, per set	IN
	03180-00943	-	Header, Muffler, 180cc, per each	IN
	03180-00944	-	Flange, Muffler, 180cc, per each	IN
	03180-00945	-	Flange, Adpater, 180cc, per each	IN

# DLA ENGINE OPERATING-INSTRUCTION MANUAL

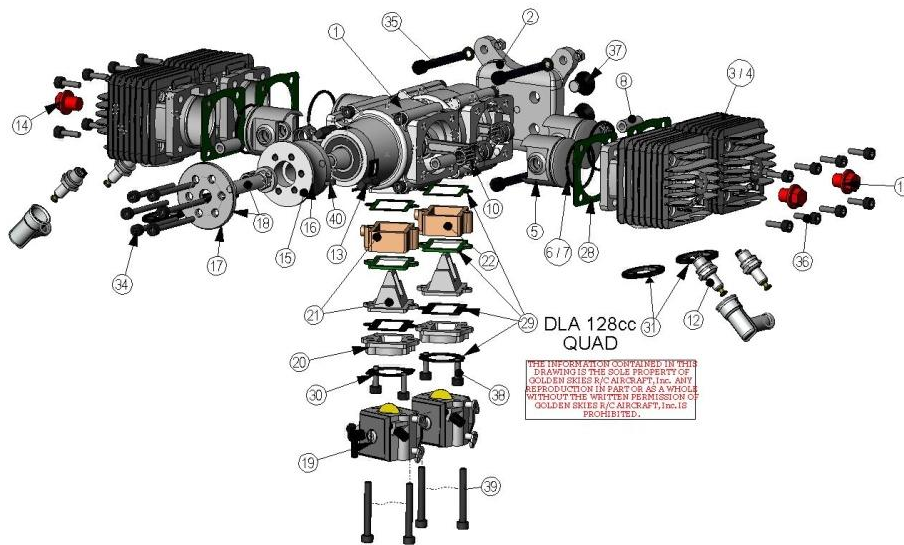
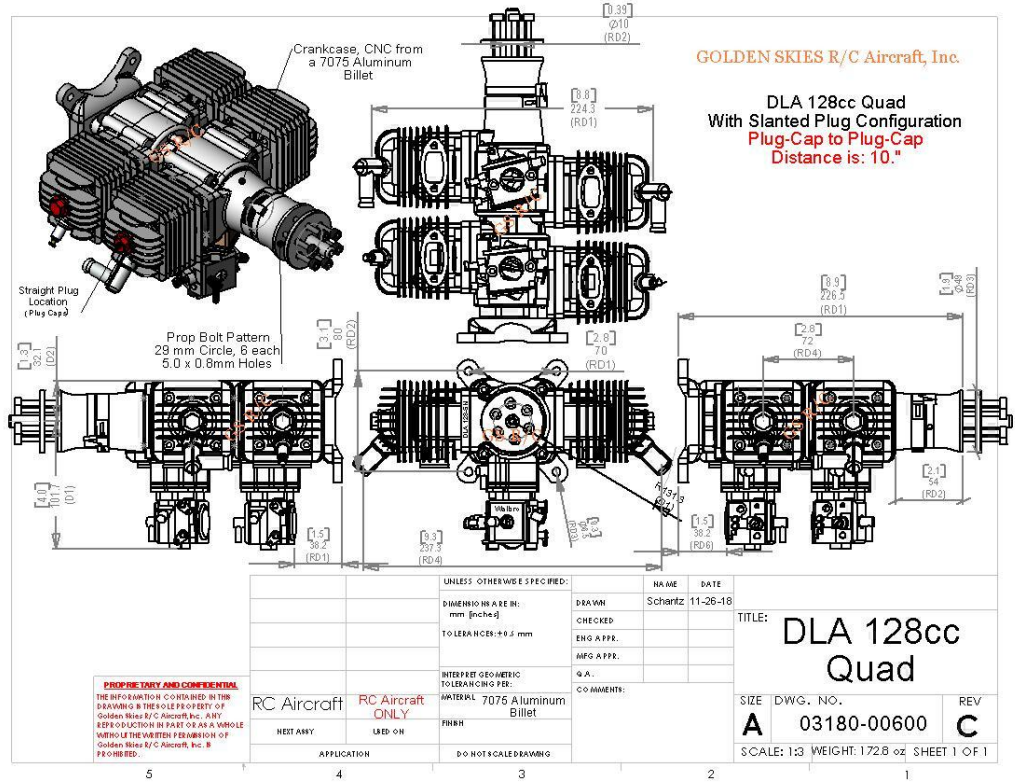



# DLA ENGINE OPERATING-INSTRUCTION MANUAL

DLA 128cc PARTS LIST - Rev: A.08.1				
FUNCTIONAL GROUPINGS	Part Numbers - Engine Components (See <a href="http://www.goldenskiesrc.com">www.goldenskiesrc.com</a> for current lists and Prices)			
	DLA 128	Dwg Key #	Part Description	Stock
Short Block	03180-00601	1	<b>Short-Block 128-Quad</b> - Assembled, , Incls: Crankcase, Crankshaft, Con-rods, 1-Assembly, per assembly.	IN
	03180-00602	2	Mount Plate, Rear, 128cc, 1-pcs, per each	IN
	03180-00620	41	Standoffs, Engine Mounting, 128cc, 4- pcs, per set of 4	IN
Heads	03180-01105	3	Cylinder Head, 32 / 64 / 128cc <b>STRAIGHT PLUG</b> Conf., 1-pcs, per each	IN
	03180-01127	4	Cylinder Head, 32 / 64 / 128cc <b>SLANTED PLUG</b> Conf., 1-pcs, per each	IN
Drive Train	03180-01108	5	Piston, 32 / 64 / 128cc (Incls: Wrist-pin & 2 ea retainer clips), 4-pcs, per set	IN
	03180-01109	6	Ring, Piston, 32 / 64 / 128cc, <b>DLA Factory</b> , 1-pcs, per each	IN
	03180-01128	7	Rings, Piston, <b>BOWMAN</b> 32,64, 128cc, 1-pcs, per each	IN
	03180-01122	8	Wrist-Pin, Piston, Con-rod, 32 / 64 / 128cc, 1-pcs, per each	IN
	03180-01126	9	Retainers, Piston Pin, 32 / 64 / 128cc, 2-pcs, per set	IN
	03180-01121	10	Bearing Needle, Connecting-rod wrist-pin, 32 / 64cc, 12mm (IKO Bearing)	IN
Ignition	10	11	Ignition Module, Capacitive Discharge., 64 / 112 / 116 / 128 / 180cc, 1-pcs, per each	IN
	03180-01114	12	Spark Plug, Iridium (All DLA Engines), 1-pcs, per each	IN
	03180-00117	13	Sensor, Ignition, w/mounting screws (All DLA Engines), 1-pcs, per each	IN
	03180-01116	14	Plug & Copper Gasket, Sparkplug Hole, All Engines. 2-pcs, per set	IN
Front End	03180-01419	15	Hub, Propeller, Washer, Propeller, 116cc, 116cc-I2 128cc, 2-pcs, per set	IN
	03180-01440	16	Prop-Hub, Only, 116 / 128cc, 1-pcs, per each	IN
	03180-01429	17	Prop Wash, Only, 116 / 128cc, 1- pcs, per each	IN
	03180-01424	18	Propeller Shaft, Crankshaft Extension, 1-pcs, per each	IN
	03180-01133	40	Key, Woodruff, All New Engines, 13.7 x 4.33 x 3 mm, 1- pcs, per each	IN
Induction Stack	03180-01411	19	Carburetor, <b>116 / 128cc</b> , Complete, Walbro WJ71 - 311	IN
	03180-00603	20	BASE, Carburetor, 1-pcs, per each	IN
	03180-01215	21	Reed Valve Assembly, Carburetor, 64 / 128cc, 2-pcs, per set	IN
	03180-01435	22	Reed-Value Housing / Heat Block, 116 / 128cc, 1-pcs, per each	IN
Bearings	03180-00604	23	Bearing Set, Front & Rear, Crankshaft (FAG), 128cc, 1-pcs, per each	IN
	03180-01605	24	Bearing, Front, (FAG), 1-pcs, per each	IN
	03180-00606	25	Bearing, Rear, (FAG), 1-pcs, per each	IN
Muffler	03180-00607	26	Muffler, 128cc, per each, 1-pcs per each (Specify Left or Right)	IN
	03180-00632	42	Canister-Muffler, 1-pcs, per each	IN
	03180-01633	43	Header, Flexible, 1-pcs, per each	IN
Gaskets	03180-00608	27	Gasket Set, Muffler, Carburetor, Head, 128cc, 16-pcs, per set	IN
	03180-01230	28	Gasket, Cylinder Head, 32 / 64 / 128cc, 1-pcs, per each	IN
	03180-00609	29	Gaskets, Induction Set, 4-pcs, per set	IN
	03180-00610	30	Gasket, Carburetor, 32 / 64 / 128cc, 1-pcs, per each	IN
	03180-00611	31	Gasket, Muffler, 2-pcs, per set of 2	IN
Bolts	0318000612	32	Bolt Set Complete, 34-pcs, Per Set	IN
	03180-00613	33	Bolt Set: Muffler, 128cc, 4-pcs, per Set	IN
	03180-00614	34	Bolt, Propeller, 1-pcs, per each	IN
	03180-00615	35	Bolts, Mounting, Washers & Nut, 5-pcs, per set	IN
	03180-00616	36	Bolts, Head, 4- pcs, per set of 4	IN
	03180-00617	37	Bolts, Mounting Plate to Crankcase, (Flat Head), 4-pcs,	IN
	03180-00618	38	Bolts, Carburetor Mounting Plate, 4-pcs, per Set	IN
	03180-00619	39	Bolts, Carburetor, 2-pcs, per Set of 2	IN



# DLA ENGINE OPERATING-INSTRUCTION MANUAL

GOLDEN SKIES R/C AIRCRAFT, INC.

## DLA 232cc Quad

Plug Cap to Plug Cap Distance:

- Slanted Plugs: 284.2 mm (11-3/16")
- Straight Plugs: 311.2 mm (12-1/4")

DLA 232cc may be configured to operate with either a *slanted plug* or a *straight plug*, by interchanging the sparking and the plug cap.

PROPELLER HOLES: 688  
6.2mm on a 36mm Dia Circle

<p><b>PROPRIETARY AND CONFIDENTIAL</b></p> <p>THE INFORMATION CONTAINED IN THIS DRAWING IS THE SOLE PROPERTY OF Golden Skies R/C Aircraft, Inc. ANY REPRODUCTION IN PART OR AS A WHOLE WITHOUT THE WRITTEN PERMISSION OF Golden Skies R/C Aircraft, Inc. IS PROHIBITED.</p>	APPLICATION	UNLESS OTHERWISE SPECIFIED:	DRAWN	NAME	DATE	TITLE:
	<p>NEXT ARMY</p> <p>R/C Model Aircraft</p>	<p>USED ON</p> <p>R/C Model Aircraft Only</p>	<p>DIMENSIONS ARE IN:</p> <p>mm (Inches)</p>	<p>CHECKED</p>	<p>Schantz</p>	<p>2-7-2020</p>
						<p>SIZE DWG. NO.</p> <p><b>A</b> 03180-02000</p>
						<p>REV</p> <p><b>B</b></p>

SCALE: 1:3.5 WEIGHT: 10.8 lb SHEET 1 OF 1

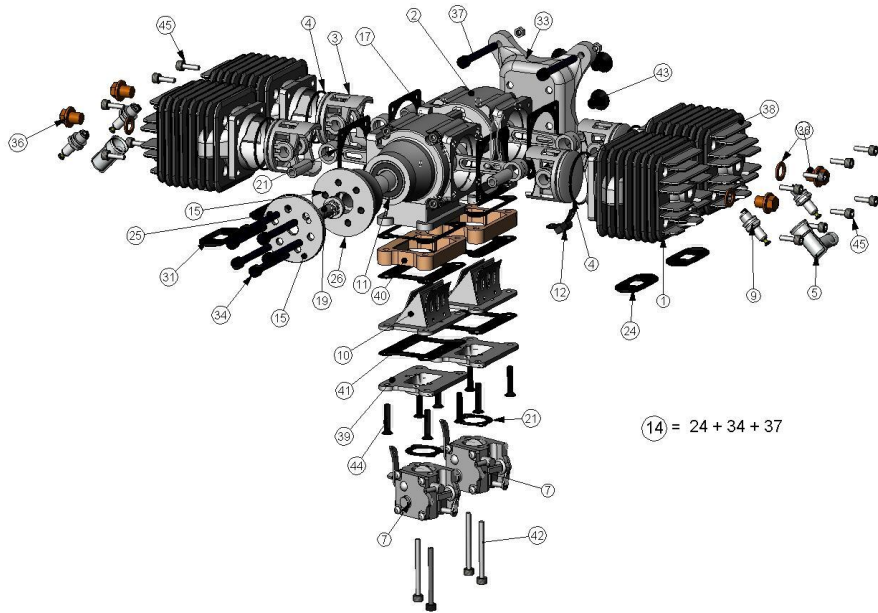

# DLA ENGINE OPERATING-INSTRUCTION MANUAL

## DLA 232cc PARTS LIST - Rev: A.08

**Part Numbers - Engine Components**  
(See [www.goldenskiesrc.com](http://www.goldenskiesrc.com) for current lists and Prices)

DLA 232 Part Number	Dwg Key #	Part Description
03180-01205	1	Cylinder Head, 58, 116, 232 cc, <b>Straight Plug Config</b>
01380-01243	1-S	Cylinder Head, 58cc, <b>Slanted Spark Plug Configuration</b>
03180-02006	2	<b>Short-Block</b> 232-Quad - Assembled, , Incls: Crankcase, Crankshaft, Con-rods, All Main Bearings, Gasket Set.
03180-02020	19	Propeller Shaft, Crankshaft Extension, 232cc, ea
03180-02019	15	Hub, Propeller, Washer, Propeller, 232cc
03180-02022	25	Key, Woodruff, 232cc
03180-02024	26	Prop-Hub (Only, 232cc
03180-01223	25	Prop Washer, Only, 232cc
03180-01629	33	Mount Plate, Engine, Rear, 232cc
03180-02012	-	Standoffs, Engine Mounting, & Bolts, 232cc
03180-01208	3	Piston & Wrist Pin w/retainers, 58, 116, 116-I2, 232cc
03180-01209	4	Ring, Piston, 58, 116, 116-I2, 232 cc
03180-01228	4-B	<b>Rings, BOWMAN</b> , 58cc / 116cc / 232cc, ea
03180-01222	17	Wrist-Pin, Piston, , Con-rod, 58cc / 116cc / 232cc. Ea
03180-01226	-	Retainers, Piston Pin. 58cc / 116cc / 232cc. Set of 8
03180-02009	5	Ignition Module, Capacitive Discharge., 232cc
03180-01114	9	Spark Plug, Iridium (All DLA Engines)
03180-00117	12	Sensor, Ignition, w/mounting screws (All DLA Engines)
01380-01239	-	Tachometer, (All DLA Engines)
03180-02010	-	Muffler, Can - <b>Std</b> , 232cc, (ea)
03180-01411	7	Carburetor, <b>116 / 232cc</b> , Complete, Walbro WJ71 - 311
03180-02014	10	Reed Valve Assembly, Carburetor, 232cc
03180-01435	40	Heat Block / Reed-Value Housing, 116, 116-I2, 232 cc
03180-01223	-	Reed Values, Only, 232cc
01380-01225	39	Mounting Plate, Carburetor, 232cc, ea
03180-02031	-	Choke or Throttle Connecting Linkage and Ball-end Connectors, 232 Quad
03180-02015	11	Bearing Set, Front & Rear, Crankshaft (FAG), 232cc
03180-01221	-	Bearing Needle, Connecting-rod wrist-pin, 58c / 116cc / 232cc, <b>13 mm</b>
03180-02034	14	Bolt Set, <b>ALL</b> , Complete, 54-pcs, per set
03180-02025	-	Bolt, <b>Muffler</b> , (all DLA Engines, ea)
03180-01338	36	<b>Plug &amp; Gasket</b> , Sparkplug <b>Hole</b> , All Engines., 2-pcss, per set
03180-02033	34	Bolts, <b>Prop</b> 6 x 1.0 -60 mm, 1-pcs, per each
03180-01436	42	<b>Bolts, Carburetor</b> , 2 -pcs, per set
01380-01227	43	Bolts, <b>Engine Mounting Plate</b> , 1-pcs, per each
03180-01228	44	Bolt, <b>Carburetor Mounting Plate</b> , Flat Head, 1-pcs, per each
03180-02025	45	Bolt, <b>Head</b> , 5 x 0.8 -16 mm, 1-pcs, per each
03180-00947	37	Bolts, Nuts, Washers, Engine Mounting, 16-pcs, per set
03180-02018	-	Bolts, <b>Crankcase</b> , 4-pcs, per set
	-	Gasket Set, ALL, 18-pcs, per set
03180-01230	21	Gasket, <b>Cylinder Head</b> , 58cc / 116cc / 232cc. 1-pcs, per each
03180-02021	22	Gasket, <b>Carburetor</b> , 232cc, 1-pcs, per each
01380-01226	21-40-41	Gasket Set, <b>Induction Stack</b> , 232cc, 4-pcs, per set
03180-01234	24 / 31	Gasket, <b>Muffler</b> , 58cc / 116cc / 232cc, 1-pcs, per each
03180-01223	24-S	Gasket, <b>Muffler</b> , & Bolts / Lock washers, 232cc, 8-pcs, per set

**CARBURETOR TUNING and CARE:**

A tachometer is required for initial carburetor tuning and is a good idea for subsequent tuning. **Remember to never adjust the carburetor while the engine is running.**

The carburetor's high and low mixture valves have been preset at the factory; however, different altitudes and climates may require minor adjustments. Turning the mixture adjustment-screws clockwise, leans the mixture and turning the screws counter-clockwise richens the mixture. If you get completely out tune, reset the mixture controls as follows:

1. **High Adjust:** Turn the Needle Valve Screw clockwise until it stops, then counter-clockwise 1-1/2 to 1-3/4 turns.
2. **Low Adjust:** Turn the Needle Valve Screw clockwise until it stops, then start at 1-turn counter-clockwise and advance to 1-1/4 (in 1/16 turns) as needed to start engine.
3. **Factory Default Setting for the Low and High Needle Valves:**

<b>DLA Engines: Low &amp; High Needle Settings</b>										
--	--	--	--	--	--	--	--	--	--	--

Engine	32	58	64	64-I2	116	116-I2	128	180	232	360
Low	1.2	1.6	1.5	1.2	1.3	1.6	1.2	1.4	1.2-1.3	1.5
High	1.3	1.5	1.7	1.3	1.5	1.5	1.3	1.5	1.3-2.0	2.6
Idle rpm	2000	1800	1600	1400	1500	1500	1500	15100	1500	1500
Highest rpm	8000	8000	8000	8000	6500	6500	6400	6200	6200	6200

**IMPORTANT:** When turning either mixture adjustments clockwise to the stop point, take care not to over tighten and destroy the valve seat. A "TWO-FINGER" hold on the screw driver provides a light touch and a reasonable feel for the stop point.

**Adjust the High Mixture:** (Clockwise leans the mix and increases the rpm. Counter-clockwise richens the mix and generally decreases the rpm.)

1. Start the engine and measure the rpm.
2. Adjust the High mixture to achieve maximum rpm (engine stopped).
3. Turn High mixture counter-clockwise (richen) until the rpm drops to 100 to 200 rpm less than the maximum rpm.
4. Return to idle, and idle for approximately sixty (60) seconds.
  - a. Be sure the idle rpm is constant and smooth.
  - b. If the idle is too rich, the rpm may slow until the engine stops.
    - i. Adjust accordingly.
5. Check the Low to High throttle transition, by somewhat rapidly moving the transmitters throttle control from idle to maximum.
  - a. See "Trouble Shooting" if the transition is not smooth and responsive.

**Adjusting the Mechanical "Idle" Screw:**

# DLA ENGINE OPERATING-INSTRUCTION MANUAL

1. The Mechanical Idle Adjustment Screw is simply a mechanical advancement or decrement of the carburetor's butterfly throttle.
2. Adjust to the Mechanical Adjustment Screw to the lowest idle that keeps the engine running and does not cause any aircraft forward motion at idle rpm.
3. If you plan to stop the engine by completely closing the butterfly-throttle, then you will need to remove the Mechanical Idle Adjustment Screw or back it out far enough to allow the butterfly to completely close. Do not attempt to remove the spring that returns the butterfly valve to the low position.

**NOTE:** On the 116cc-I2 and the 128cc QUAD richen the high-needle on the rear cylinder/bank carburetor by about 1/16 to 3/32 turns to help cool these cylinders, if they are running too hot; or even more so, in the event of a particularly hot flying day.

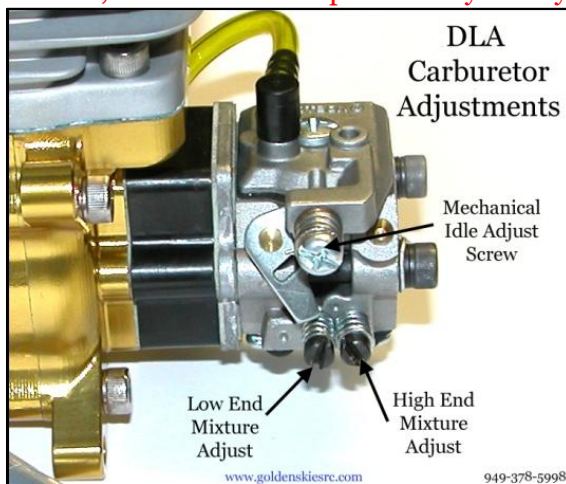

DLA32cc Carb

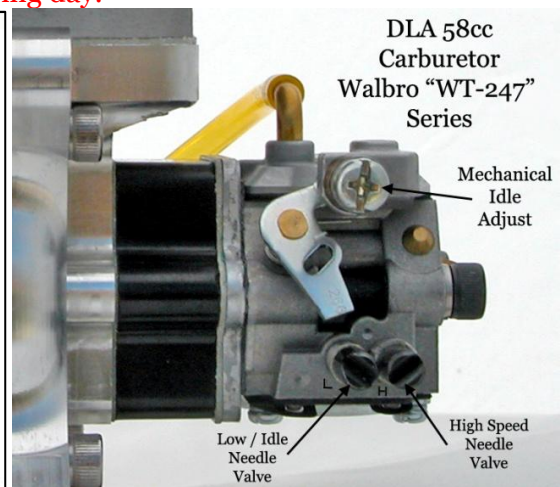

DLA 58cc Carb

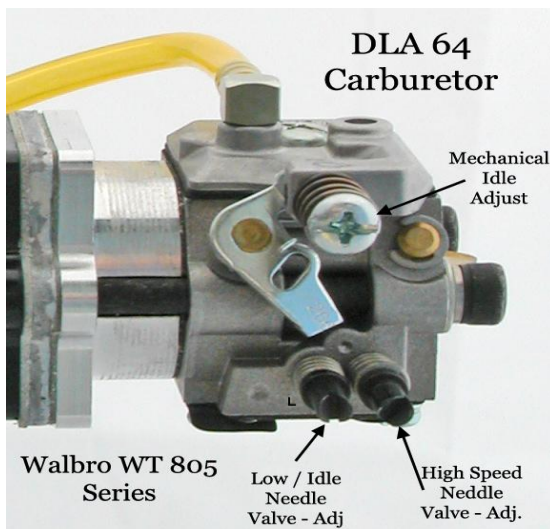

DLA 64cc Carb



DLA 116cc Carb



**Carburetor Cleaning:** The carburetor screen will need to be cleaned periodically. Clean the screen with clean, fresh gasoline or Carburetor cleaner and blow off with compressed air. Also check the choke and throttle butterfly for tightness.

#### Carburetor Repair Kits:

Engine	Carburetor Type	Diaphragm / Gasket Kit	Repair Kit
32	Tillotson™, HU-134A	03180-00118	03180-RK-31HU
58	Walbro™, WT-247 Series	03180-00131	03180-00TBD
64	Walbro™, WT-805 Series	03180-00230	03180-K20-WAT
64-I2	Tillotson™, HU-134A	03180-00118	03180-RK-31HU
116	Walbro™, WJ-71 Series	03180-00330	03180-K10-WJ
116-I2	Walbro™	03180-00xx	TBD
180cc	Walbro™ WB-25	TBD	KU 11 WB
128cc	Walbro™ HDA	03180-00xxx	03180-K20-WAT
232cc	Walbro™ WJ-71	TBD	TBD

#### TROUBLE SHOOTING:

### TROUBLE SHOOTING GUIDE

#### ALWAYS STOP ENGINE WHEN MAKING ADJUSTMENTS

#	Problem / Symptom	Possible Solution
1	Engine is Flooded with fuel	1) <b>Turn kill switch to OFF</b> , Remove Sparkplug. , Blow out and dry plug electrodes, Turn engine to where the cylinder head is pointed down, Drain Fuel, Rotate propeller around several times, replace sparkplug and restart engine
2	Engine starts after being choked but the stops soon thereafter	1) The low mixture valve may be too lean. Richen by turning counter-clockwise. Adjust the Low End Mixture needle valve to achieve a smooth idle and a reliable transition to high throttle. Generally, if the engine stutters or coughs in the mid range during low to high transition or when the throttle is advanced, the Low End needle is too lean and possibly the High End Needle valve is too lean.



3	Engine runs rough and vibrates strongly	1) Check the propeller balance, 2) Balance Propeller as needed, 3) Check engine to firewall mounting bolts for security, 4) Check tank to engine plumbing for air leaks, 5) Check sparkplug for carbon build up (an indication that gas:oil mix is too low or rich with oil) 6) Check sparkplug gap, 7) Check all bolts for tightness and security, 8) Make sure the engine is not mounted in a bias, that is the crankcase is being twisted by the mounting misalignment, the ends of the stand-offs should be in the same plane.
4	Engine does not reach a "normal" high rpm at full throttle	1) Check carburetor settings, particularly the High End Mixture Needle Valve, 2) Check to see that the propeller is NOT larger than specified in the DLA engine specifications, 3) Check for engine overheating ... a sign that gas:oil mix is too lean, that is too little oil, 4) Check ignition timing, 5) Confirm you are using the correct size muffler, 6) Verify proper gas:oil mixture.
5	Engine hesitates or pauses when throttle is transitioned from Low to High (especially when throttle is advanced rapidly)	1) Low End Mixture Needle Value is too Lean. Open (Counterclockwise) ~ 1/16 to 1/8 turn at a time and test again.
6	Idle rpm is not steady or smooth	1) Low End Mixture Needle Valve is too Rich, 2) Close (Clockwise) ~ 1/16 to 1/8 turn at a time and test again.
7	Engine Stalls or stops at High or Full Throttle	1) The High End Mixture Needle Valve is too lean, 2) Open High Mix 1/16 to 1/8 turns and test again.

**OIL and Oil:Gas Mixture Table**

A table of Gasoline to Oil ratios has been provided for your use. (Appendix A) Another useful source for determining the oil quantity to be added to a specified amount of gasoline can be found at:

[www.csgnetwork.com/oilfuelcalc.html](http://www.csgnetwork.com/oilfuelcalc.html)

**Precision measuring, mixing cups** are available from: KAM-TECH, LLC, 2147 W. 236<sup>th</sup> Street, Torrance, CA 90501, 310-257-1240; “Ratio Rite Measuring Cup”

There are multiple sources of high quality oil available. Several are listed below:

<u>Band</u>	<u>Type</u>	<u>Typical Mix Ratio</u>
• AMSOIL Professional Saber	Synthetic	40:1 to 45:1
<a href="http://www.amsoil.com/shop/by-product/motor-oil/2-stroke/saber-professional/?page=%2fstorefront%2fatp.aspx">www.amsoil.com/shop/by-product/motor-oil/2-stroke/saber-professional/?page=%2fstorefront%2fatp.aspx</a>		
• Red Line	(NOT TESTED)	40:1
• Royal Purple	(NOT TESTED) Synthetic	40:1
• Bell Ray (Honda)	(NOT TESTED)	
• Yamalube	Tested Blend	40 : 1
• Torco T-2R	Tested Blend	40 : 1
• Klotz, R50, Super X2 or BIA Grade	(NOT TESTED), Synthetic	45 : 1
• Stihl HP Ultra	Excellent Synthetic	40:1
• Castor Oil TTR		35:1

**The above oils are not for break-in but for normal flying after the break-on period.**

**WARRANTY:**

The DLA Manufacturer warrants DLA engines to be free of defects at the time of purchase. The DLA 32cc, 58cc, 64cc and 116cc Gas Engines have a **two (2) year** limited warranty, from the date of purchase, when purchased from a GOLDEN SKIES R/C AIRCRAFT, Inc. distribution retailer. The DLA warranty is granted only to the original engine purchaser and is not transferable or assignable. During the warranty period, GOLDEN SKIES R/C AIRCRAFT, Inc. will, at the discretion of GOLDEN SKIES R/C AIRCRAFT, Inc., repair and/or replace engine parts that do not meet original factory specifications. All DLA engines must be marked with a factory Serial Number for the warranty to apply. The 116-I2 and 128cc QUAD retains a two (2) year warranty.

**Warranty Extensions:**

- If the DLA engine is purchased through a GOLDEN SKIES R/C AIRCRAFT, Inc. authorized retailer, a third (3<sup>rd</sup>) year of warranty may be purchased for \$40.00 at the time of warranty registration. The original purchaser must purchase the third (3<sup>rd</sup>) year of warrant directly from GOLDEN SKIES R/C AIRCRAFT, Inc. when the purchaser registers the engine with GOLDEN SKIES R/C AIRCRAFT, Inc. All terms and conditions of warranty registration apply.
- If the DLA engine is purchased directly from GOLDEN SKIES R/C AIRCRAFT, Inc., the warranty period will be three (3) years. The 116-I2 and 128cc engines have a two (2) year warranty.

Golden Skies R/C Aircraft, Inc. does not honor the warranty on any DLA engine(s) purchased from outside the Golden Skies R/C Aircraft distribution channel. Upon request and authorization from GOLDEN SKIES R/C AIRCRAFT, INC., DLA engines purchased outside the GOLDEN SKIES R/C AIRCRAFT, INC. distribution channel may be serviced by GOLDEN SKIES R/C AIRCRAFT, INC. The consumer will be charged the current retail cost of parts and the current, associated hourly labor rate to repair the engine. All other terms and conditions specified by FeiaoModel and/or Golden Skies R/C Aircraft herein apply to a DLA engine purchased outside the Golden Skies R/C Aircraft distribution Channel.

**Warranty Registration** must occur with seven (7) days of the original purchase date. The original purchaser must register the DLA engine with Golden Skies R/C Aircraft, and provide the following:

- Date and place of Purchase, copy of Sales Receipt.
- Engine Serial Number.
- Name, address, phone and E-mail address of Original Purchaser.
  - The purchaser assumes the responsibility of maintaining a current email address with GOLDEN SKIES R/C AIRCRAFT, Inc.

The Warranty does not cover any of the following:

- Damage caused by:
  - Improper Handling.
  - Improper Operation.
  - Disassembly, in any way, of the Engine or Carburetor System.
    - Disassembly will invalidate the warranty.
  - Engine or Carburetor Modifications.

- Damage caused by trauma, impact or crashes
- Damage caused by use of improper fuels or oils, or mixtures thereof.
  - 87 or 89 Octane, unleaded gasoline is all that is allowed.
- Interior Rubber Carburetor parts are normal “Wear and Tear” parts.  
**NOTE:** Gas / Alcohol mixtures or Alcohol additives to the gas are known to accelerate deterioration of carburetor rubber parts.
- Damage caused by Fuel or Gas Additives other than what is described in this operations manual.
- Damage cause by improper ignition battery selection.
- Damage incurred during transit to or from the repair facility.
- Stripped or cross-threading bolts or spark-plug(s).
- Damage as a result of improper electrical wiring connections.
- Damage caused by overheating the engine.
- Tune-ups, including the sparkplug(s).
- Any other use of the DLA engine(s) for purposes other than powering a Model Aircraft will void the warranty.
- Shipping Charges to and return from the GS R/C service center

#### HOW TO OBTAIN WARRANTY SERVICE:

1. Contact GS R/C for an authorization warranty return case-number.
2. Return the following to GS R/C:
  - a. Engine
  - b. Muffler(s)
  - c. Sparkplug(s)
  - d. Ignition
3. Ship the items listed in #2 above to: (GS R/C is not responsible for shipment loss or shipment damage.)  
Golden Skies R/C Aircraft, Inc.  
Service Dept.  
30882 Rivera Place  
Laguna Niguel, CA 92677
4. Insure the Engine for the purchase Price or as follows whichever is more:
 

a. DLA 32cc Engine	\$ 310.00
b. DLA 58cc Engine	\$ 400.00
c. DLA 64cc Engine	\$ 589.00
d. DLA 116cc Engine	\$ 690.00
e. DLA 116cc I2 Engine	\$ 889.00
f. DLA 128cc QUAD	\$ 1,440.00
g. DLA 180cc	\$ 1,199.00
h. DLA 232cc	\$ 1,749.00
5. Include a typed and signed explanation of the engines problem(s)
6. The GOLDEN SKIES R/C AIRCRAFT, INC. Service Department will respond with a written estimate for labor charges.
7. Damaged parts or parts that do not meet factory specification will not be return to the sender.
8. Provide full purchaser information: Name, address, phone #, email address.

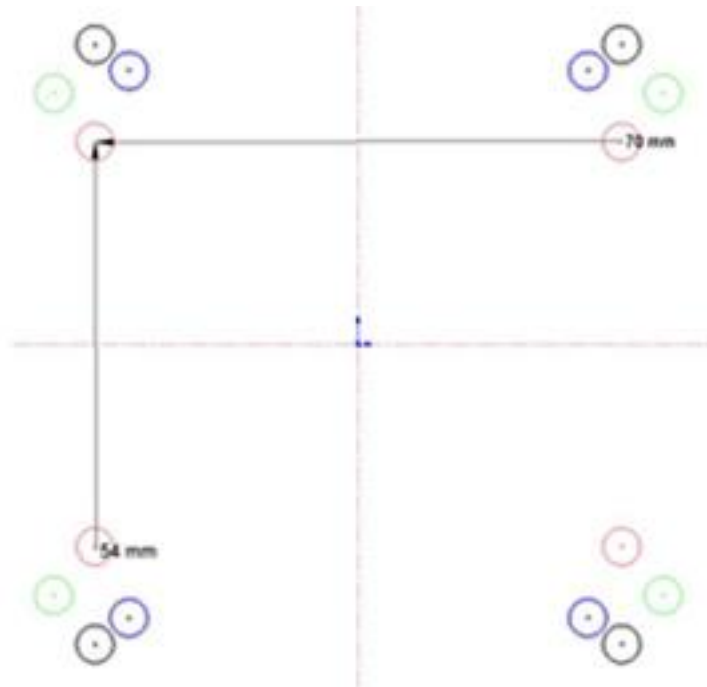
**Dimensioned Mounting Template (paper)****Table 1**

Engine	Template Hole Color	X <sub>c/c</sub> - Dimension	Y <sub>c/c</sub> - Dimension
<b>32 cc</b>	Red	70 mm (2.75")	54 mm (2.13")
<b>58 cc</b>	Green	76 mm (2.99")	63.5 mm (2.50")
<b>64 cc (Twin Boxer)</b>	Blue	61 mm (2.40")	73 mm (2.87")
<b>64-I2 (inline)</b>		78 mm (3.07")	65 mm (2.56")
<b>116 cc (Twin Boxer)</b>	Black	70 mm (2.75")	80 mm (3.15")
<b>116-I2cc (inline)</b>	---	70 mm (2.75")	80 mm (3.15")
<b>128cc (QUAD)</b>	---	70 mm (2.75")	80 mm (3.15")
<b>180cc</b>	---	80 mm (3.15")	90 mm (3.54")
<b>232cc (Quad)</b>	---	80 mm (3.15")	90 mm (3.54")
	---		

**Always verify (Measure) the above paper template, Mounting Diagram Dimensions.**



**Table 2 - DLA Published Specifications****DLA 32cc (1.97 in<sup>3</sup>) Gas Engine**

Power:	3.8 HP @ 8200 rpm
Idle Speed:	1,350 - 1,700 rpm
Static Thrust:	19.4 pounds @ 100 m (~328 ft) (Pulling Force) 17.2 pounds @ 1,800 m (~5,900 ft)
Propellers:	18 x 8 / 10, 19 x 8, 20 x 8
Carburetor:	Tillotson™, HU-134A
CDI Voltage:	6.4 – 8.4 VDC
Spark Plug:	CM-6 Special, Iridium
Exhaust Volume:	32.23 cc (1.97 in <sup>3</sup> )
Cylinder Diameter / Stroke:	37 mm / 30 mm (1.46 in / 1.18")
Compression Ratio:	7.6 : 1
Gas : Oil Ratios:	25 – 30 : 1 Break-in Trial Run; 40 – 50 : 1 Normal Flying
Weights:	Engine 32.1 oz, Muffler: 2.3 oz, Ignition 3.5 oz

**DLA 58cc (3.54 in<sup>3</sup>) Gas Engine**

Power:	6.0 @ HP @ 8500 rpm
Idle Speed:	1,400 -1,500 rpm
Static Thrust:	33.1 pounds @ 100 m (~328 ft) (Pulling Force) 29.1 pounds @ 1,800 m (~5,900 ft)
Propellers:	22 x 10, 23 x 8/10, 24 x 8
Carburetor:	Walbro™, "WT-xxx" Series
Spark Plug:	CM-6 Special, Iridium
CDI Voltage:	6.4 – 8.4 VDC
Exhaust Volume:	58 cc (3.54 in <sup>3</sup> )
Cylinder Diameter / Stroke:	46 mm / 35 mm (1.77 in / 1.38")
Compression Ratio:	7.8 : 1
Gas : Oil Ratios:	25 – 30 : 1 Break-in Trial Run; 40 – 50 : 1 Normal Flying
Weights:	Engine 49.1 oz, Muffler: 3.87 oz, Ignition 4.76 oz

**DLA 64cc (3.91 in<sup>3</sup>) Gas Engine (Twin Boxer)**

Power:	7.2 @ HP @ 8500 rpm
Idle Speed:	1,400 rpm
Static Thrust:	34.4 pounds @ 100 m (~328 ft) (Pulling Force) 30.4 pounds @ 1,800 m (~5,900 ft)
Propellers:	22 x 10, 23 x 8/10, 24 x 8
Carburetor:	Walbro™, "WT-xxx" Series
CDI Voltage:	6.4 – 8.4 VDC
Spark Plug:	CM-6 Special, Iridium
Exhaust Volume:	64 cc (3.97 in <sup>3</sup> )
Cylinder Diameter / Stroke:	37 mm / 30 mm (1.46 in / 1.18")
Compression Ratio:	7.8 : 1
Gas : Oil Ratios:	25 - 30 : 1 Break-in Trial Run; 40 – 50 : 1 Normal Flying
Weights:	Engine 57.1 oz, Muffler: 2.3 x 2 ea oz, Ignition 4.76 oz

**DLA 64-I2cc (3.91 in<sup>3</sup>) Gas Engine (In-Line)**

Power:	7.6 @ HP @ 8500 rpm
Idle Speed:	1,400 rpm
Static Thrust:	35 pounds @ 100 m (~328 ft) (Pulling Force) 31 pounds @ 1,800 m (~5,900 ft)
Propellers:	22 x 10, 23 x 8/10, 24 x 8
Carburetor:	Walbro™, "WT-xxx" Series
CDI Voltage:	6.4 – 8.4 VDC
Spark Plug:	CM-6 Special, Iridium

Exhaust Volume:	64 cc	(3.97 in <sup>3</sup> )
Cylinder Diameter / Stroke:	37 mm / 30 mm	(1.46 in / 1.18")
Compression Ratio:	7.8 : 1	
Gas : Oil Ratios:	25 - 30 : 1 Break-in Trial Run; 40 - 50 : 1 Normal Flying	
Weights:	Engine 77 oz, Muffler: 4 oz, Ignition 9.2 oz	

## DLA 116cc (7.08 in<sup>3</sup>) Gas Engine (Twin Boxer)

Power:	11.8 HP @ 7500 rpm	
Idle Speed:	1,300 rpm	
Static Thrust:	59.9 pounds @ 100 m (~328 ft) (Pulling Force)	
	52.5 pounds @ 1800 m (~5,900 ft)	
Propellers:	26 x 10/12, 27 x 10, 28 x 10	
Carburetor:	Walbro™, "WJ-xx" Series	
CDI Voltage:	6.4 - 8.4 VDC	
Spark Plug:	CM-6 Special, Iridium	
Exhaust Volume:	116 cc	(7.08 in <sup>3</sup> )
Cylinder Diameter / Stroke:	46 mm / 35 mm	(1.77 in / 1.38")
Compression Ratio:	7.8 : 1	
Gas : Oil Ratios:	25 - 30 : 1 Break-in Trial Run; 40 - 50 : 1 Normal Flying	
Weights:	Engine 88.8 oz, Muffler: 4.05 x 2 ea oz, Ignition 6.34 oz	

## DLA 116cc I2 (7.08 in<sup>3</sup>) Gas Engine (In-Line)

Power:	12.8 HP @ 7500 rpm	
Idle Speed:	1,200 rpm	
Static Thrust:	61.8 pounds @ 100 m (~328 ft) (Pulling Force)	
	55.1 pounds @ 1800 m (~5,900 ft)	
Propellers:	27 x 10/12, 28 x 10, 29 x 10	
Carburetor:	Walbro™, "WJ-" Series	
CDI Voltage:	6.4 - 8.4 VDC	
Spark Plug:	CM-6, Iridium Special	
Exhaust Volume:	116 cc	(7.08 in <sup>3</sup> )
Cylinder Diameter / Stroke:	46 mm / 35 mm	(1.77 in / 1.38")
Compression Ratio:	7.8 : 1	
Gas : Oil Ratios:	25 - 30 : 1 Break-in Trial Run; 40 - 50 : 1 Normal Flying	
Weights:	Engine: 102.3 oz (6.39 lbs), Muffler: 12.3 oz, Ignition: 6.34 oz	

## DLA 128cc (7.81 in<sup>3</sup>) Gas Engine

Power:	13.0 HP @ 7500 rpm	
Idle Speed:	1,250 rpm	
Static Thrust:	62.0 pounds @ 100 m (~328 ft) (Pulling Force)	
	56.8 pounds @ 1,800 m (~5,900 ft)	
Propellers:	27 x 10/12, 28 x 8/10, 29 x 10	
Carburetor:	Walbro™, "WT-xxx" Series	
CDI Voltage:	6.4 - 8.4 VDC	
Spark Plug:	CM-6 Special, Iridium	
Exhaust Volume:	128 cc	(7.81 in <sup>3</sup> )
Cylinder Diameter / Stroke:	37 mm / 30 mm	(1.46 in / 1.18")
Compression Ratio:	7.8 : 1	
Gas : Oil Ratios:	25 - 30 : 1 Break-in Trial Run; 40 - 50 : 1 Normal Flying	
Weights:	Engine: 120 oz (7.49 lbs), Muffler: 9.57 x 2 ea oz, Ignition 12.6oz	

## DLA 180cc (10.98 in<sup>3</sup>) Gas Engine

Power:	> 18 HP @ 7,500 rpm	
Idle Speed:	1,000 -1,250 rpm	
Static Thrust:	> 90 pounds @ 100 m (~328 ft) (Pulling Force)	

# DLA ENGINE OPERATING-INSTRUCTION MANUAL

Propellers:	> 81 pounds @ 1,800 m (~5,900 ft)
Carburetor:	32 x 10 / 12 / 14, 33 x 10
CDI Voltage:	Walbro™, "WT-xxx" Series
Spark Plug:	6.4 – 8.4 VDC
Exhaust Volume:	CM-6 Special, Iridium
Cylinder Diameter / Stroke:	180 cc (10.98 in <sup>3</sup> )
Compression Ratio:	mm / mm (in /in)
Gas : Oil Ratios:	7.8 : 1
Weights:	25 – 30 : 1 Break-in Trial Run; 40 – 50 : 1 Normal Flying
	Engine: 129.0 oz (8.1 lbs); Muffler: oz; Ignition: oz

## DLA 232cc (14.6 in<sup>3</sup>) Gas Engine

Power:	> 23 HP @ 7,500 rpm
Idle Speed:	~ 1,150 rpm
Static Thrust:	>100 pounds @ 100 m (~328 ft) (Pulling Force)
	> 90 pounds @ 1,800 m (~5,900 ft)
Propellers:	34 x 10, 35 x 10/12, 36 x 10 2-Blade, 28x14, 30x12, 32x12 3-Blade
Carburetor:	Walbro™, "WT-xxx" Series
CDI Voltage:	6.4 – 8.4 VDC
Spark Plug:	CM-6 Special, Iridium
Exhaust Volume:	232 cc (14.6 in <sup>3</sup> )
Cylinder Diameter / Stroke:	mm / mm (in /in)
Compression Ratio:	7.8 : 1
Gas : Oil Ratios:	25 – 30 : 1 Break-in Trial Run; 40 – 50 : 1 Normal Flying
Weights:	Engine: 172.8 oz; Muffler: 15.8 oz; Ignition: 15.2 oz

## Engine Bolt Torques:

DLA Engines Bolt TORQUES (inch * lbs)					
	DLA 32	DLA 56 / 58	DLA 64	DLA 112 / 116	DLA 128cc
Prop-Bolts	40	62	62	80	80
Prop-Shaft Extension	257	296	301	301	301
Crank-Case Bolts	80	106	124	124	124
Spark Plug	90	90	90	90	90
Head / Cylinder Bolts	80	106	97	106	97
Carburetor Bolts	53	62	62	62	62
Muffler Bolts					
Engine Mounting					
Other					
Spark Plug Gap	0.18"	0.18"	0.18"	0.18"	0.18"
Ignition Sensor Advance (Degrees)	~30°	~30°	~30°	~30°	~30°

# DLA ENGINE OPERATING-INSTRUCTION MANUAL

## Appendix A

### DLA Engine Gas and Oil Mixture Table

Gas Volume to be Mixed (Gallons)	RATIOS											
	Break-in Ratios						Normal Flying Ratios					
	30 : 1		32 : 1		35 : 1		40 : 1		45 : 1		50 : 1	
	oz	ml	oz	ml	oz	ml	oz	ml	oz	ml	oz	ml
0.25	1.1	31.5	1.00	29.6	0.91	27.0	0.80	23.7	0.71	21.0	0.64	18.9
0.50	2.1	63.1	2.00	59.1	1.83	54.1	1.60	47.3	1.42	42.1	1.28	37.9
0.75	3.2	94.6	3.00	88.7	2.74	81.1	2.40	71.0	2.13	63.1	1.92	56.8
<b>1.00</b>	<b>4.3</b>	<b>126.2</b>	<b>4.00</b>	<b>118.3</b>	<b>3.66</b>	<b>108.2</b>	<b>3.20</b>	<b>94.6</b>	<b>2.84</b>	<b>84.1</b>	<b>2.56</b>	<b>75.7</b>
1.25	5.3	157.7	5.00	147.9	4.57	135.2	4.00	118.3	3.56	105.1	3.20	94.6
1.50	6.4	189.3	6.00	177.4	5.49	162.2	4.80	141.9	4.27	126.2	3.84	113.6
1.75	7.5	220.8	7.00	207.0	6.40	189.3	5.60	165.6	4.98	147.2	4.48	132.5
<b>2.00</b>	<b>8.5</b>	<b>252.4</b>	<b>8.00</b>	<b>236.6</b>	<b>7.31</b>	<b>216.3</b>	<b>6.40</b>	<b>189.3</b>	<b>5.69</b>	<b>168.2</b>	<b>5.12</b>	<b>151.4</b>
2.25	9.6	283.9	9.00	266.2	8.23	243.3	7.20	212.9	6.40	189.3	5.76	170.3
2.50	10.7	315.4	10.00	295.7	9.14	270.4	8.00	236.6	7.11	210.3	6.40	189.3
2.75	11.7	347.0	11.00	325.3	10.06	297.4	8.80	260.2	7.82	231.3	7.04	208.2
<b>3.00</b>	<b>12.8</b>	<b>378.5</b>	<b>12.00</b>	<b>354.9</b>	<b>10.97</b>	<b>324.5</b>	<b>9.60</b>	<b>283.9</b>	<b>8.53</b>	<b>252.4</b>	<b>7.68</b>	<b>227.1</b>
3.25	13.9	410.1	13.00	384.4	11.89	351.5	10.40	307.6	9.24	273.4	8.32	246.0
3.50	14.9	441.6	14.00	414.0	12.80	378.5	11.20	331.2	9.96	294.4	8.96	265.0
3.75	16.0	473.2	15.00	443.6	13.71	405.6	12.00	354.9	10.67	315.4	9.60	283.9
4.00	17.1	504.7	16.00	473.2	14.63	432.6	12.80	378.5	11.38	336.5	10.24	302.8
4.25	18.1	536.3	17.00	502.7	15.54	459.6	13.60	402.2	12.09	357.5	10.88	321.8
4.50	19.2	567.8	18.00	532.3	16.46	486.7	14.40	425.8	12.80	378.5	11.52	340.7
4.75	20.3	599.3	19.00	561.9	17.37	513.7	15.20	449.5	13.51	399.6	12.16	359.6
<b>5.00</b>	<b>21.3</b>	<b>630.9</b>	<b>20.00</b>	<b>591.5</b>	<b>18.29</b>	<b>540.8</b>	<b>16.00</b>	<b>473.2</b>	<b>14.22</b>	<b>420.6</b>	<b>12.80</b>	<b>378.5</b>
5.25	22.4	662.4	21.00	621.0	19.20	567.8	16.80	496.8	14.93	441.6	13.44	397.5
5.50	23.5	694.0	22.00	650.6	20.11	594.8	17.60	520.5	15.64	462.6	14.08	416.4
5.75	24.5	725.5	23.00	680.2	21.03	621.9	18.40	544.1	16.36	483.7	14.72	435.3
6.00	25.6	757.1	24.00	709.7	21.94	648.9	19.20	567.8	17.07	504.7	15.36	454.2
6.25	26.7	788.6	25.00	739.3	22.86	675.9	20.00	591.5	17.78	525.7	16.00	473.2
6.50	27.7	820.1	26.00	768.9	23.77	703.0	20.80	615.1	18.49	546.8	16.64	492.1
6.75	28.8	851.7	27.00	798.5	24.69	730.0	21.60	638.8	19.20	567.8	17.28	511.0
7.00	29.9	883.2	28.00	828.0	25.60	757.1	22.40	662.4	19.91	588.8	17.92	529.9
7.25	30.9	914.8	29.00	857.6	26.51	784.1	23.20	686.1	20.62	609.9	18.56	548.9
7.50	32.0	946.3	30.00	887.2	27.43	811.1	24.00	709.7	21.33	630.9	19.20	567.8
7.75	33.1	977.9	31.00	916.8	28.34	838.2	24.80	733.4	22.04	651.9	19.84	586.7
8.00	34.1	1009.4	32.00	946.3	29.26	865.2	25.60	757.1	22.76	672.9	20.48	605.6
8.25	35.2	1041.0	33.00	975.9	30.17	892.2	26.40	780.7	23.47	694.0	21.12	624.6
8.50	36.3	1072.5	34.00	1005.5	31.09	919.3	27.20	804.4	24.18	715.0	21.76	643.5
8.75	37.3	1104.0	35.00	1035.0	32.00	946.3	28.00	828.0	24.89	736.0	22.40	662.4
9.00	38.4	1135.6	36.00	1064.6	32.91	973.4	28.80	851.7	25.60	757.1	23.04	681.4
9.25	39.5	1167.1	37.00	1094.2	33.83	1000.4	29.60	875.4	26.31	778.1	23.68	700.3
9.50	40.5	1198.7	38.00	1123.8	34.74	1027.4	30.40	899.0	27.02	799.1	24.32	719.2
9.75	41.6	1230.2	39.00	1153.3	35.66	1054.5	31.20	922.7	27.73	820.1	24.96	738.1
<b>10.00</b>	<b>42.7</b>	<b>1261.8</b>	<b>40.00</b>	<b>1182.9</b>	<b>36.57</b>	<b>1081.5</b>	<b>32.00</b>	<b>946.3</b>	<b>28.44</b>	<b>841.2</b>	<b>25.60</b>	<b>757.1</b>

# DLA ENGINE OPERATING-INSTRUCTION MANUAL

## DLA ENGINE GAS UTILIZATION:

Gas Consumption								
Low rpm Consumption					High rpm Consumption			
Engine Model	Speed (rpm)	Minimum consumption (gal/hr)	Minimum consumption (gal/min)	Minimum consumption oz/min	Speed (rpm)	Maximum consumption (gal/hr)	Maximum consumption (gal/min)	Maximum consumption oz/min
DLA32	3,000	0.07	0.0012	0.158	7,300	0.452	0.0075	0.964
DLA58	2,000	0.15	0.0026	0.327	6,200	0.481	0.0080	1.026
DLA64	2,000	0.13	0.0022	0.276	7,200	0.671	0.0112	1.432
DLA64-I2	2,000	0.13	0.0022	0.276	7,200	0.671	0.0112	1.432
DLA116	2,000	0.20	0.0033	0.423	6,300	1.358	0.0226	2.897
DLA116-I2	2,000	0.20	0.0033	0.423	6,300	1.358	0.0226	2.897
DLA128	2,000	0.26	0.0043	0.552	6,400	1.302	0.0217	2.778
DLA180	2,000	0.24	0.0040	0.513	6,000	2.161	0.0360	4.610
DLA232	2,000	0.38	0.0063	0.806	6,700	3.067	0.0511	6.543
DLA360	2,000	0.44	0.0074	0.947	7,000	3.659	0.0610	7.806

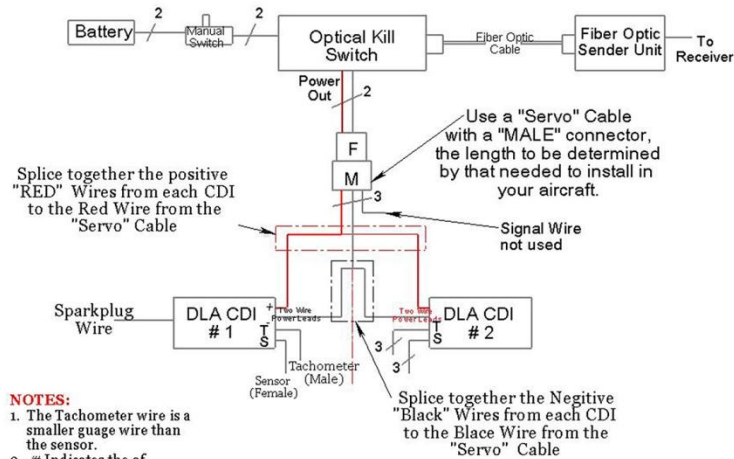

## APPENDIX B

Wiring Diagram for Multi-Cylinder Engines with  
Dual Ignition and an Optical Kill Switch**NOTES:**

1. The Tachometer wire is a smaller gauge wire than the sensor.
2. # Indicates the of Wires in Cable/ Leads
3. T=> Tachometer Cable
- S=> Sensor Cable
4. "Servo" Cable should be 22 AWG or larger